



# Port Kembla Gas Terminal

**Erosion and Sediment Control Plan  
Stage 2A and 2B Marine Berth  
Construction and Dredging – Land and  
Marine Based**

Australian Industrial Energy

30 May 2022

→ **The Power of Commitment**



**GHD Pty Ltd | ABN 39 008 488 373**









133 Castlereagh Street, Level 15

Sydney, New South Wales 2000, Australia

T +61 2 9239 7100 | F +61 2 9239 7199 | E [sydmal@ghd.com](mailto:sydmal@ghd.com) | [ghd.com](http://ghd.com)

<b>Printed date</b>	30/05/2022 9:36:00 AM
<b>Last saved date</b>	30 May 2022
<b>File name</b>	\\ghdnet\ghd\AU\Sydney\Projects\21\27477\Tech\MP update\Stage 2B\Spoil Management Plan\App D - Erosion and Sediment Control Plan\PKGT-AIE-ESCP-Stage-2A&2B_RevD (TC).docx
<b>Author</b>	Nathan Alexander
<b>Project manager</b>	Karl Rosen
<b>Client name</b>	Australian Industrial Energy
<b>Project name</b>	East Coast Gas Project
<b>Document title</b>	Port Kembla Gas Terminal   Erosion and Sediment Control Plan Stage 2A and 2B Marine Berth Construction and Dredging – Land and Marine Based
<b>Revision version</b>	Rev D
<b>Project number</b>	2127477
<b>AIE document number</b>	PKGT-AIE-PLN-033

**Document status**

Status Code	Author	Reviewer		Approved for issue		
		Name	Signature	Name	Signature	Date
A	N Alexander	K Rosen		K Rosen		28/01/22
B	N Alexander	K Rosen		K Rosen		22/02/22
C	N Alexander	K Rosen		K Rosen		23/03/22
D	N Alexander	K Rosen		K Rosen		30/05/22

© GHD 2022

This document is and shall remain the property of GHD. The document may only be used for the purpose for which it was commissioned and in accordance with the Terms of Engagement for the commission. Unauthorised use of this document in any form whatsoever is prohibited.

# Acronyms

Acronym	Definition
AHD	Australian Height Datum
AIE	Australian Industrial Energy
ARI	Average Recurrence Interval
ASRIS	Australian Soil Resource Information System
ASS	Acid Sulfate Soils
ASSMP	Acid Sulfate Soils Management Plan
Berth 101	Marine Berth Construction and Dredging
Blue Book	Managing Urban Stormwater: Soils and Construction – Volume 1 “the Blue Book”
BOM	Bureau of Meteorology
CPESC	Certified Professional in Erosion and Sediment Control
CSP	Contaminated Spoil Protocol
CSSI	Critical State-Significant Infrastructure
CTMP	Construction Traffic Management Plan
DEMP	Dredge and Excavation Management Plan
DP&E	Department of Planning and Environment
ECR	Emplacement Cell Report
EIS	Environmental Impact Statement
EMS	Environmental Management Strategy
EP&A Act	<i>Environmental Planning and Assessment Act 1979</i>
EPL	Environment Protection Licence
ESCP	Erosion and Sediment Control Plan
FSRU	Floating Storage and Re-gasification Unit
GHD	GHD Pty Ltd
GML	General Mass Limits
HM	Harbour Muds
HS	Harbour Silts
HSE	Health, Safety and Environment
IECA	International Erosion Control Association
KPIs	Key Performance Indicators
LNG	Liquefied Natural Gas
m <sup>3</sup>	Cubic metres
MBD	Marine Berth Construction and Dredging
mbgl	metres below ground level
MLA	Marine Loading Arms
OHDSCA	Outer Harbour Dredged Spoil Containment Area
ORF	Onshore Receiving Facilities
PANSW	Port Authority of NSW
PASS	Potential Acid Sulfate Soils

<b>Acronym</b>	<b>Definition</b>
PESCP	Progressive Erosion and Sediment Control Plan
PKGT	Port Kembla Gas Terminal
PKGT EIS	Port Kembla Gas Terminal Environmental Impact Statement
PKHD	Port Kembla Height Datum
Planning Systems SEPP	State Environmental Planning Policy (Planning Systems) 2021
POEO Act	<i>Protection of the Environment Operations Act 1997</i>
POMP	Port Operations Management Plan
RL	Reduced level
RoW	Right of Way
RUSLE	Revised Universal Soil Loss Equation
SEPP	State Environmental Planning Policy
SMEC	SMEC Australia Pty Ltd
SMP	Spoil Management Plan
SLC	Soil Loss Class
The Project	Port Kembla Gas Terminal Project
Wollongong DCP	Wollongong Development Control Plan 2009
Wollongong LEP	Wollongong Local Environmental Plan 2009
WQMP	Water Quality Monitoring Plan

# Contents

<b>1. Introduction</b>	<b>1</b>
1.1 Overview	1
1.2 Background	1
1.3 Purpose	2
<b>2. Project overview</b>	<b>3</b>
2.1 Site description	3
2.2 Project construction scope of works	5
2.3 Stage 2A: Construction of quay wall (MBD – Land Based)	9
2.4 Stage 2A: Power, communications, and water connections	11
2.5 Stage 2A: Construction of ORF	11
2.6 Stage 2B: Excavation and dredging	12
2.7 Stage 2B: Construction of the Emplacement Cell	16
<b>3. Roles and responsibilities</b>	<b>17</b>
<b>4. Legislative requirements</b>	<b>19</b>
<b>5. Planning requirements</b>	<b>20</b>
5.1 Conditions of approval	20
5.2 Environment Protection Licence	23
<b>6. Existing environment</b>	<b>24</b>
6.1 Topography	24
6.2 Soils and geology	24
6.3 Acid Sulfate Soils (ASS)	24
6.4 Contaminated soils	24
6.5 Climate	25
<b>7. Progressive Erosion and Sediment Control Plans</b>	<b>26</b>
7.1 Development of PESCPs	26
7.2 Design criteria	26
<b>8. Management and mitigation measures</b>	<b>30</b>
<b>9. Monitoring and inspections</b>	<b>40</b>
<b>References</b>	<b>41</b>

## Table index

Table 2.1	Construction stages/work packages	5
Table 2.2	Marine berth and wharf structures to be constructed during Stage 2A	9
Table 2.3	Construction of power connections for Stage 2A	11
Table 2.4	Structures to be constructed for ORF during Stage 2A	11
Table 2.5	Marine based construction works during Stage 2B	13
Table 2.6	Emplacement Cell key features – Stage 2B	16
Table 3.1	Roles and responsibilities of Project Team	17

Table 4.1	Legislation and relevant policy applicable to this ESCP	19
Table 5.1	Planning requirements	21
Table 5.2	EPL No. 21529 conditions	23
Table 6.1	Average rainfall (mm) data for Port Kembla Signal Station (068053) (BOM, 2019)	25
Table 7.1	RUSLE factors	26
Table 7.2	Erosion risk and annual soil loss for the Project	27
Table 7.3	Minimum design standards (DECC, 2008)	27
Table 7.4	Typical ESC practices for pipelines (IECA, 2008)	28
Table 8.1	Mitigation/management measures for erosion and sedimentation during Stage 2A and Stage 2B	30

## Figure index

Figure 2.1	Site overview	4
Figure 2.2	Stage 2A and Stage 2B works and location of MBD Site Compound, Emplacement Cell and Emplacement Cell Construction Site	6
Figure 2.3	Layout of MBD Site Compound	7
Figure 2.4	Layout of Emplacement Cell Construction Site	8
Figure 2.5	Location of quay wall and layout of MBD and ORF	10
Figure 2.6	Dredging and excavation works for MBD Site Compound (Stage 2B)	14
Figure 2.7	Emplacement Cell overview (Stage 2B)	15
Figure 6.1	Average rainfall (mm) graph for Port Kembla Signal Station (068053) (BOM, 2019)	25
Figure 7.1	Typical ROW trench up slope of vehicle access track (IECA, 2008)	29
Figure 7.2	Typical layout of erosion controls Option E1 (IECA, 2008)	29
Figure 7.3	Sediment control option S2 (IECA, 2008)	29

## Appendices

Appendix A	Standard design drawings
------------	--------------------------

# 1. Introduction

## 1.1 Overview

This Erosion and Sediment Control Plan (ESCP) has been developed as a Sub - plan to the Port Kembla Gas Terminal Project (the Project) Spoil Management Plan (SMP). The SMP is Sub - plan to the Project's overarching Environmental Management Strategy (EMS). This ESCP has been prepared by GHD Pty Ltd (GHD) on behalf of Australian Industrial Energy (AIE) to apply to construction activities associated with Stage 2A and Stage 2B of the Project. This Stage 2A and Stage 2B ESCP supersedes the Stage 2A ESCP.

This ESCP interfaces with the other associated Sub - plans, which together describe the proposed structure for environmental management and monitoring requirements for the Project. This ESCP addresses the requirements of the Port Kembla Gas Terminal Environmental Impact Statement (PKGT EIS) and associated Infrastructure Approval (SSI 9471) and Environment Protection Licence (EPL) No. 21529.

## 1.2 Background

AIE is developing the Project which involves the development of a liquefied natural gas (LNG) import terminal at Port Kembla, south of Wollongong, NSW. The Project will be the first of its kind in NSW and will provide a simple and flexible solution to the state's gas supply challenges.

NSW currently imports more than 95 percent of the natural gas it uses from other eastern states. In recent years, gas supplies to the Australian east coast market have tightened, resulting in increased natural gas prices for both industrial and domestic users.

The Project provides an immediate solution to address the predicted shortages and will result in significant economic benefits for both the Illawarra region and NSW. The Project will have a capacity to deliver more than 100 petajoules of natural gas, equivalent to more than 70 percent of NSW gas needs and will provide between 10 to 12 days of natural gas storage in case of interstate supply interruption. LNG will be sourced from worldwide suppliers and transported by LNG carriers to the gas terminal at Port Kembla where it will be re-gasified for input into the NSW gas transmission network.

The Project has been declared Critical State Significant Infrastructure (CSSI) in accordance with Section 5.13 of the *Environmental Planning and Assessment Act 1979* (EP&A Act) (NSW) and Schedule 5 of the State Environmental Planning Policy (Planning Systems) 2021 (Planning Systems SEPP). The Project received Infrastructure Approval from the Minister for Planning and Public Spaces on 29 April 2019.

The construction of the Project is primarily associated with the establishment of a new berth facility at Port Kembla to enable an LNG carrier to berth alongside the Floating Storage and Re-gasification Unit (FSRU) and new infrastructure to connect the terminal to the existing gas network. Excavation and dredging would be required to establish the new berth facility, with spoil deposited in a cell (referred to as the 'Emplacement Cell') in the Outer Harbour.

The development has progressed to Stage 2A and Stage 2B works located at Berth 101 (referred to as the 'Marine Berth Construction and Dredging (MBD) Site Compound') and the Outer Harbour Dredged Spoil Containment Area (referred to as 'OHDSKA' or the Emplacement Cell). Collectively, these two locations are referred to as "the site". The Stage 2A works include:

- Completion of excavation works undertaken during Stage 1 (including transport of spoil materials to the Emplacement Cell Construction Site).
- Construction of the quay wall at the MBD Site Compound.
- Construction of Onshore Receiving Facilities (ORF) at the MBD Site Compound (including construction of Wharf Topside Area, Utility Area, and Common Area).
- Installation and commissioning of power, communications, and potable water.
- Installation of gas pipeline within the MBD Site Compound as part of ORF.

The Stage 2B works include:

- Continuation of Stage 2A works.

- Excavation and dredging of the MBD Site Compound in the Inner Harbour and the Emplacement Cell in the Outer Harbour.
- Construction of the Emplacement Cell in the Outer Harbour.
- Marine based construction activities including installation of navigational aids and revetments at the MBD Site Compound.

## 1.3 Purpose

This ESCP has been prepared in accordance with the PKGT EIS and associated Infrastructure Approval (SSI 9471) and EPL No. 21529. It describes how the management measures and commitments in the PKGT EIS, Infrastructure Approval (SSI 9471) and EPL No. 21529, relating to erosion and sediment controls are to be implemented by the Principal Contractor's during Stage 2A and Stage 2B construction of the Project. Specifically, this plan addresses the following requirements:

- Minimise the impacts of erosion and sedimentation during construction to surrounding environments.
- Ensure appropriate erosion and sediment control measures are implemented across the Project to meet regulatory, statutory and community expectations and requirements.
- Ensure that best practice erosion and sediment controls are appropriately adopted and designed, following the Managing Urban Stormwater: Soils and Construction (Landcom, 2004) also known as the "Blue Book".
- Provide a measurable set of commitments for site inspections and audits with regards to management of soils and water.
- Promote a focus on erosion control and the prevention of sediment generation.

This plan addresses the above requirements and includes, but is not limited to:

- Performance criteria for erosion and sediment control mitigation.
- Mitigation strategies to minimise impacts related to erosion and sediment control.

AIE and its contractors acknowledge that maintaining erosion and sediments in the vicinity of the Project site is paramount to the successful delivery of the construction phase of the Project. AIE is committed to ensuring this ESCP is implemented, reviewed and updated regularly to ensure its objectives are met and that the conditions outlined in the Infrastructure Approval (SSI 9471) and EPL No. 21529 are achieved.

This ESCP is applicable to all staff, employees, subcontractors, and any statutory service authorities undertaking the Stage 2A and Stage 2B works described in Section 2 of this ESCP.

This ESCP is an overarching plan that provides guidance to the development of Progressive Erosion and Sediment Control Plans (PESCPs), which are specific to various sites (e.g., MBD Site Compound and Emplacement Cell Construction Site). The PESCP for the MBD Site Compound has been developed and is progressively updated by the Stage 2A Principal Contractor as required. The PESCP for the Emplacement Cell Construction Site (Drawings ESCP01 and ESCP02, Revision 5, dated 30 August 2021) will not require updating and will remain applicable for the current condition of the Emplacement Cell Construction Site. The ESCP implementation and on-going development will be managed by the Project Team (refer to Section 3).



## 2. Project overview

### 2.1 Site description

The site of the Project is situated at Port Kembla within the Illawarra region of NSW, about 80 kilometres south of Sydney. Port Kembla is mainly characterised by an existing import and export terminal and multiple other business, cargo, logistics, bulk goods, and heavy industrial facilities in the vicinity.

Port Kembla is situated about two kilometres south of the centre of Wollongong. Other localities surrounding Port Kembla and the Project site include Mangerton, Mount St. Thomas and Figtree to the north-west; Unanderra to the west; Berkeley to the south-west; and Cringila, Lake Heights, Warrawong and the residential region of Port Kembla to the south.

The zoned land use in the region includes special use and industrial use at Port Kembla and a mix of primarily residential and commercial uses at the surrounding localities. Major infrastructure in the region of Port Kembla includes the Princes Highway, which is a major state and regional highway connecting Sydney and Wollongong and regional areas further south. Princes Highway provides access to Port Kembla through turnoffs at Masters Road, Five Islands Road and Northcliffe Drive and is broadly utilised including by heavy vehicles from the port.

The South Coast railway line runs along the periphery of Port Kembla including the stations Port Kembla, Port Kembla North, Cringila and Lysaghts. The rail line services commuters and is also used to transport bulk solid goods like coal, grain, copper and steel from Port Kembla. The environmental features of Port Kembla and the surrounding region are limited given the extensive industrial, commercial and residential development. Waterways in the region include the Gurungaty Waterway, Allans Creek, American Creek and Byarong Creek. Green space includes JJ Kelly Park and Wollongong Golf Club to the north and a larger open area to the south-west.

The Project will be predominantly located within land zoned for dedicated port and industrial uses. Berth and wharf facilities, as well as the FSRU, would be situated at Berth 101 at the Inner Harbour, while the gas pipeline would extend around the periphery of port operations from Berth 101 to a tie-in point at Cringila. The Emplacement Cell will be located in the Outer Harbour. A site overview is provided as Figure 2.1.



Data source: Aerial imagery - nearmap 2022 (image date 18/04/2018, date extracted 18/02/2019), General topo - NSW LPI DTDB 2017 & 2015, Cadastre - NSW LPI DCDB 2017. Created by: eibbertson

Figure 2.1 Site overview

## 2.2 Project construction scope of works

The Project construction scope of work has been divided into three main packages (with associated activities), as outlined in Table 2.1. Construction staging of the Project has been approved in accordance with Condition 3 of Schedule 4 of Infrastructure Approval (SSI-9471) as per correspondence from the Department of Planning and Environment (DP&E) dated 27 October 2021. This ESCP applies only to the works associated with Stage 2A and Stage 2B.

Table 2.1 Construction stages/work packages

Stage	Package	Proposed commencement	Activities
1	Early Enabling Works	May 2021	Demolition of Berth 101, removal of structures and land based excavation works, and Cone Penetration Testing in the Outer Harbour to inform Emplacement Cell design and relocation of Bunker Oil Pipeline.
2A	Marine Berth Construction – Land Based	January 2022	Completion of excavation works undertaken during Stage 1. Transport of spoil materials to Emplacement Cell Construction Site. Quay wall construction.
		February 2022	Installation of communications conduit, potable water line, 11kV power cable, and padmount substation within the MBD Site Compound.
		April 2022	Construction of the ORF, which comprises three areas: Wharf Topside Area; Utility Area; and Common Area.
		June 2022	Pipeline construction and associated ancillary infrastructure within MBD Site Compound
2B	Marine Berth Construction and Dredging – Land and Marine Based	March 2022	Continuation of Stage 2A with addition of the following activities:
			Excavation/dredging of the MBD Site Compound in the Inner Harbour and construction of the Emplacement Cell in the Outer Harbour
			Marine based construction activities including installation of navigational aids and revetment shore protection.
3	Pipeline Installation including tie-ins (NGP)	June 2022	Construction of an 18" onshore natural gas pipeline approximately 6.3km in length from the Berth 101 site boundary to tie-in facility at Cringila for connection to the Eastern Gas Pipeline Pipeline construction to occur concurrently with Jemena, subject to separate set of management plans.

\*Proposed dates and may be subject to change.

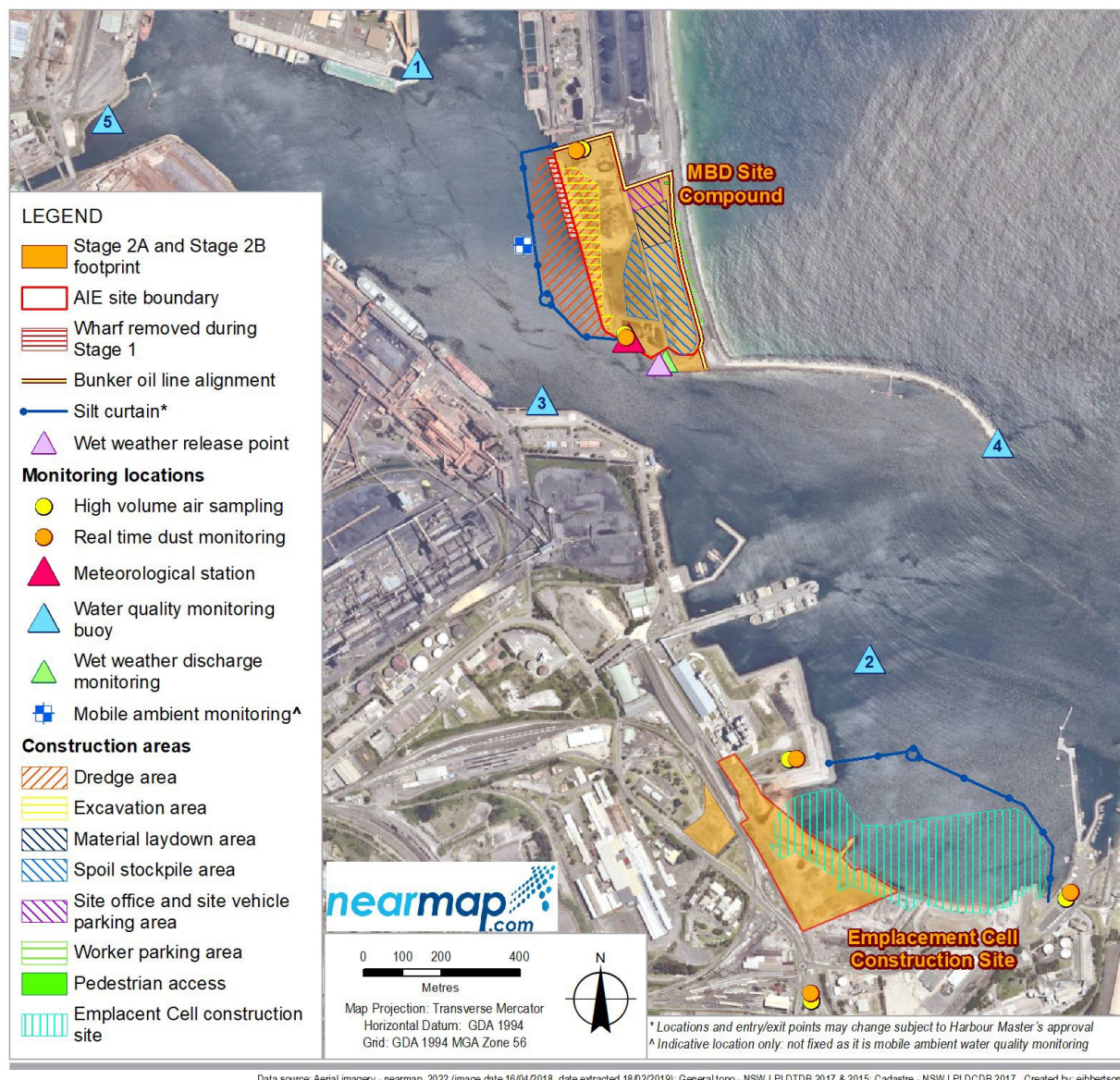
The following will be undertaken as part of the Stage 2A works:

- Construction of the quay wall at MBD Site Compound incorporating finalisation of excavation works undertaken during Stage 1 (including transport of spoil materials to Emplacement Cell Construction Site).
- Installation of and commissioning of power, communications, and potable water line.
- Construction of ORF at MBD Site Compound (including construction of Wharf Topside Area, Utility Area, and Common Area).
- Installation of gas pipeline within MBD Compound site.

The following will be undertaken as part of the Stage 2B land and marine-based works:

- Continuation of Stage 2A works.
- Installation of site facilities and preparatory earthworks at Emplacement Cell Construction Site.
- Marine-based construction activities including installation of silt curtains, navigational aids, and revetment shore protection at the MBD Site Compound.
- Construction of the Emplacement Cell in the Outer Harbour.
- Excavation and dredging of the MBD Site Compound in the Inner Harbour.

An outline of the tasks associated with Stage 2A and Stage 2B is provided in Section 2.3 through Section 2.7. The site includes the MBD Site Compound, the Emplacement Cell Construction Site, and the Emplacement Cell located in the Outer Harbour. The location of the Stage 2A and Stage 2B works is shown in Figure 2.2.



Data source: Aerial imagery - nearmap 2022 (image date 16/04/2018, date extracted 18/02/2019); General topo - NSW LPI DTDB 2017 & 2015; Cadastre - NSW LPI DCDB 2017. Created by: eibbertson

**Figure 2.2** Stage 2A and Stage 2B works and location of MBD Site Compound, Emplacement Cell and Emplacement Cell Construction Site

## 2.2.1 Traffic

Road traffic generated by Stage 2A and Stage 2B will be controlled through the gate on Sea Wall Road. Heavy vehicle movements will be generated by the delivery of materials, equipment, and plant to the MBD Site Compound and transport of stockpiled material to the Emplacement Cell Construction Site.

In addition to the material that has already been transported to Emplacement Cell Construction Site (Outer Harbour Laydown Area) during Stage 2A, up to 30,000 cubic metres (m<sup>3</sup>) of material from the MBD Site Compound is anticipated to be transported via road to the Emplacement Cell Construction Site during Stage 2B. The activities associated with this task will involve loading, road transportation via truck and trailer (approximately 30-tonne capacity), unloading, stockpiling, and management of the stockpiles.

Light vehicle movements will be generated from construction workers accessing the MBD Site Compound and Emplacement Cell Construction Site. Parking will be provided for up to approximately 100 workers on the MBD Site Compound and approximately 37 workers at the Emplacement Cell Construction Site (refer to Figure 2.3 and Figure 2.4).

Road traffic movements will be undertaken in accordance with the Stage 2A and Stage 2B Construction Traffic Management Plan (CTMP).

The road traffic generated by Stage 2B will mainly be associated with the delivery of the quarry materials from quarries located in the surrounding area. It is anticipated that about 40-50 daily truck movements will be required, consisting of three - five axle semi-trailers or rigid truck and five axle dog-trailers of less than 40 tonnes (GML). The activities will take place during the standard daytime construction working hours, averaging approximately eight heavy truck movements per hour (four vehicles in and out of site). The total number of vehicles required for the operation will be 12-16.

The majority of traffic generated during Stage 2B activities will be marine traffic movements during dredging operations. Marine traffic navigation and management will be undertaken in accordance with a Port Navigation Plan, herein referred to as the Port Operations Management Plan (POMP). The POMP has been produced by the Stage 2B Principal Contractor in consultation with the Port Authority of NSW (PANSW) and is consistent with the principles in the CTMP for Stage 2A.

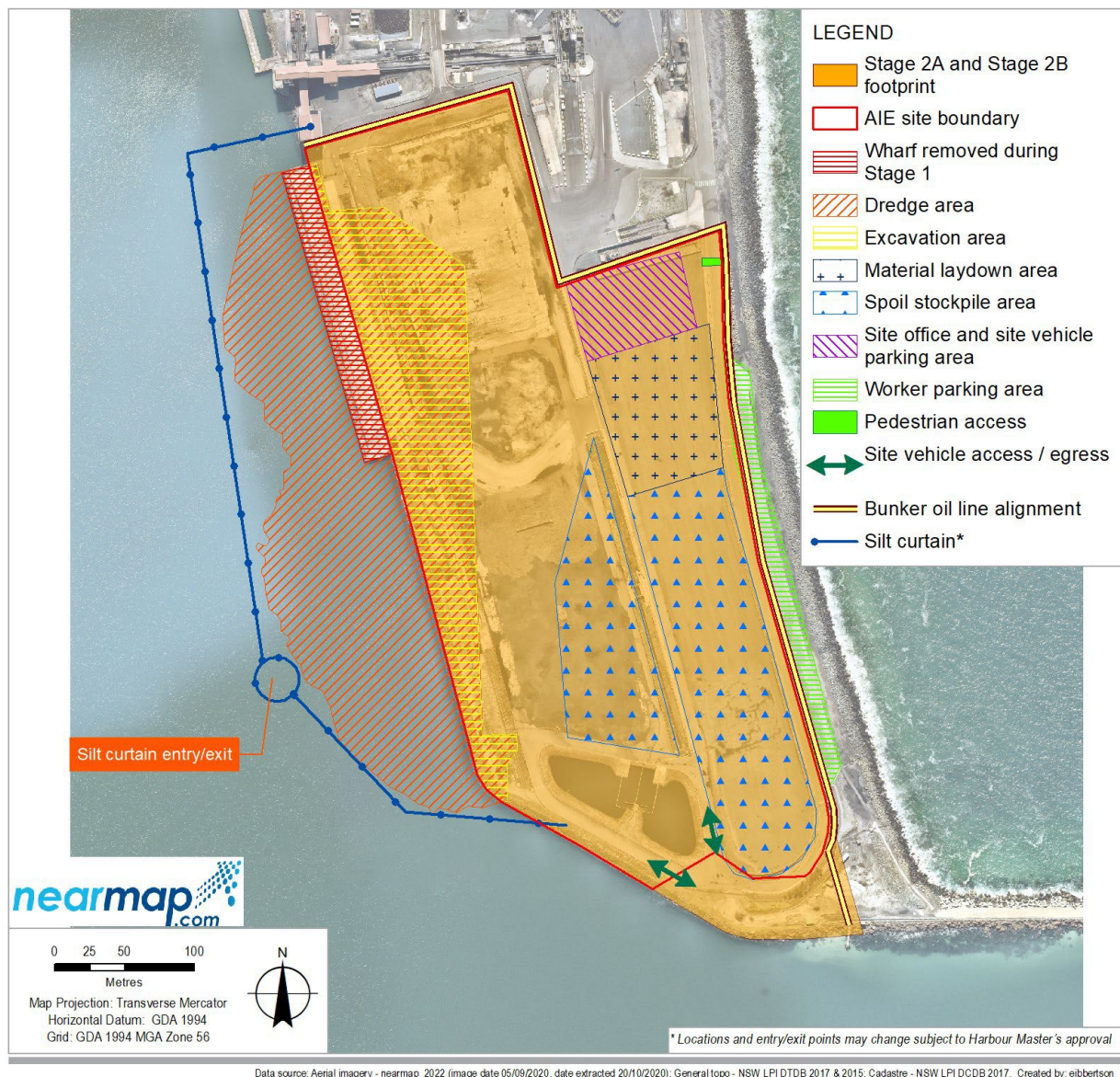
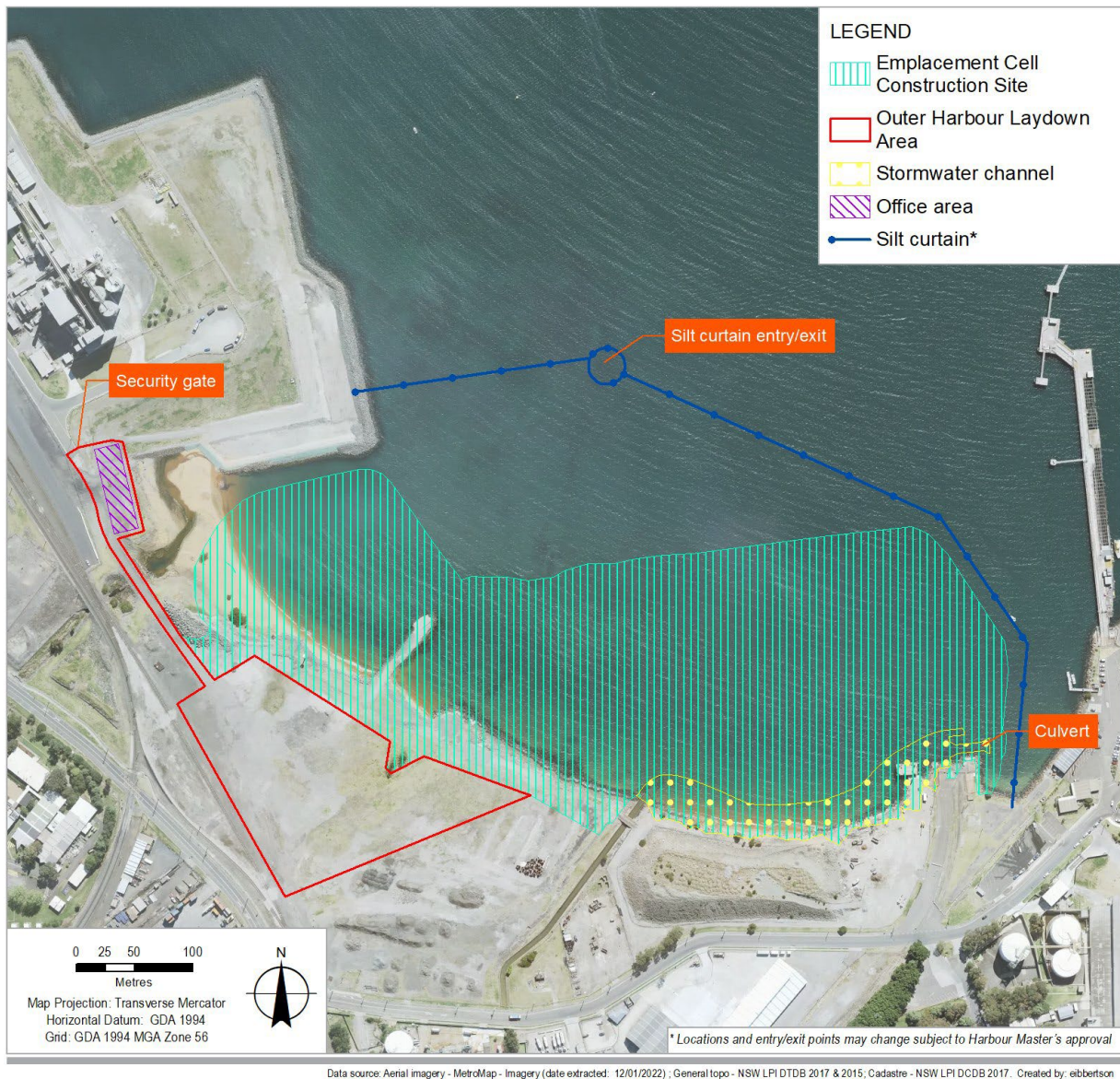


Figure 2.3 Layout of MBD Site Compound



**Figure 2.4** Layout of Emplacement Cell Construction Site

## 2.2.2 Program

The Stage 2A works commenced in January 2022. Stage 2B, which includes the continuation of land-based construction and marine-based works, are then anticipated to commence in March 2022 (refer to Table 2.1 for construction staging). As noted in Section 2.2, these dates are only proposed and may be subject to change.

## 2.3 Stage 2A: Construction of quay wall (MBD – Land Based)

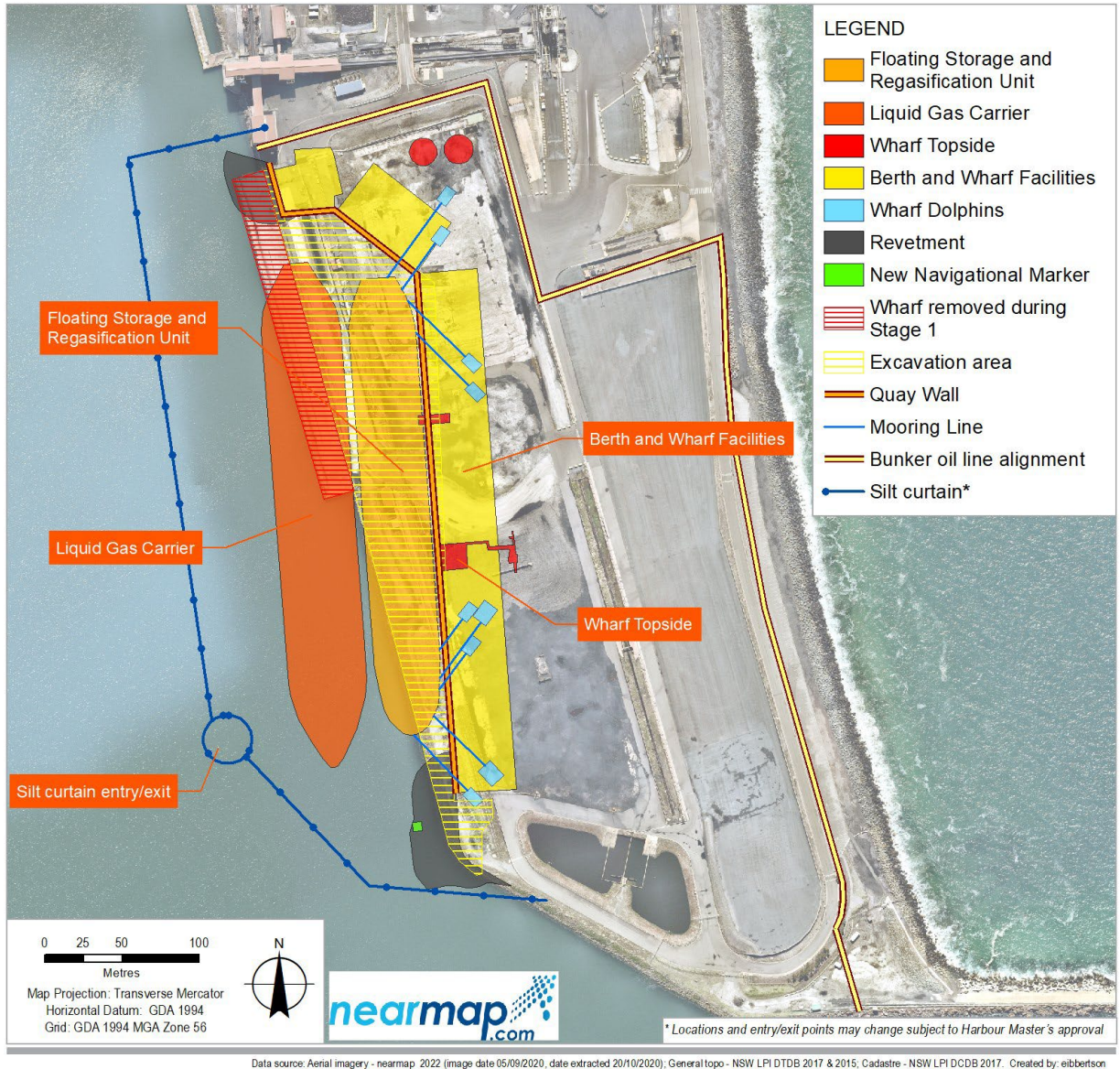
A number of structures will be constructed within the MBD Site Compound to accommodate the FSRU and LNG carrier for the Project. Excavation and stockpiling activities from the Stage 1 Early Enabling Works will continue on-site during Stage 2A to lay the platform for ongoing construction activities at the MBD Site Compound.

The new structures that will commence construction during Stage 2A are summarised in Table 2.2. The location of the quay wall and layout of the marine berth and wharf facilities is shown in Figure 2.5.

Table 2.2 Marine berth and wharf structures to be constructed during Stage 2A

Component	Works required
Earthworks and stockpiles	<ul style="list-style-type: none"> <li>– Completion of excavation and backfilling works from Stage 1 Early Enabling Works.</li> <li>– Excavated materials from the Early Enabling Works have been stockpiled within the Eastern and Western Stockyards of the MBD Site Compound and the Emplacement Cell Construction Site.</li> <li>– The excavated materials stockpiled at the MBD Site Compound include: <ul style="list-style-type: none"> <li>• Approximately 9,700m<sup>3</sup> of demolished concrete crushed to nominal 70mm minus.</li> <li>• Approximately 12,500m<sup>3</sup> of heavily bound base course crushed to nominal -150mm minus.</li> <li>• Approximately 33,900m<sup>3</sup> of mixed slag, general fill, and coal nominally &lt; 150mm in size.</li> <li>• Approximately 10,700m<sup>3</sup> of predominantly sand material.</li> <li>• Approximately 8,600 m<sup>3</sup> of asbestos impacted soils.</li> </ul> </li> <li>– The excavated materials stockpiled at the Emplacement Cell Construction Site include: <ul style="list-style-type: none"> <li>• Approximately 44,000 m<sup>3</sup> of sand material.*</li> </ul> </li> <li>– The excavated materials will be used/reused for quay wall construction and to backfill the landside area of the quay wall or transported to the Emplacement Cell Construction Site for storage and use in construction of the Emplacement Cell.</li> </ul>
Quay wall	<ul style="list-style-type: none"> <li>– Construction of a new piled quay wall keyed into bedrock where necessary complete with sheet pile anchor wall, capping beam and tie rods to the south of the existing coal terminal.</li> <li>– Excavated and processed materials from the Stage 1 Early Enabling Works are stockpiled within the MBD Site Compound and will be used during construction of the quay wall and to backfill on landside area of the wall.</li> <li>– Installation of a marine fender system attached to the capping beam along the quay wall to protect the quay wall from berthing and mooring loads.</li> <li>– Installation of a cathodic protection system to the quay wall and associated elements, including assessment of the potential impacts the FSRU and pipeline cathodic protection will have on quay wall.</li> <li>– Backfilling and compaction on landside area of wall utilising the site stockpiled materials.</li> </ul>
Mooring dolphins	<ul style="list-style-type: none"> <li>– Installation of landside mooring dolphin structures on reinforced concrete platforms supported by steel piles.</li> <li>– Mooring equipment will be installed and comprise the following: <ul style="list-style-type: none"> <li>• 20 load sensing quick release hooks.</li> <li>• Up to four land-based mooring winches on mooring dolphins may be required.</li> <li>• Up to four swivel fairleads may be required to enable each mooring line to land-based winches to be fed in a horizontal alignment.</li> </ul> </li> </ul>
Marine Loading Arm (MLA) foundations	Construction of a new reinforced concrete foundation supported on steel piles, located behind the new quay wall.
Gangway tower foundation	Construction of foundation for Gangway tower.
Fire monitor foundation	Fire monitor foundations, subject to risk studies.

\*The volumes provided are approximate and may vary.



**Figure 2.5** Location of quay wall and layout of MBD and ORF



## 2.4 Stage 2A: Power, communications, and water connections

Works required for power, communications, and water connections for Stage 2A are summarised in Table 2.3.

Table 2.3 Construction of power connections for Stage 2A

Component	Works required
Power and communications	<ul style="list-style-type: none"> <li>– Construction and installation of a new 11kV power cable in a buried conduit and Substation.</li> <li>– Energisation of the padmount substation and 415kV temporary building supply.</li> <li>– Installation of communication conduit and pits.</li> </ul>
Potable water	<ul style="list-style-type: none"> <li>– Extension of existing potable waterline within MBD Site Compound.</li> </ul>

## 2.5 Stage 2A: Construction of ORF

The general layout of the ORF areas is shown in Figure 2.5. Works required for the three ORF areas during Stage 2A are summarised in Table 2.4.

Table 2.4 Structures to be constructed for ORF during Stage 2A

Component	Works required
<b>Wharf Topside Area</b>	
Marine Loading Arms (MLAs)	Installation of MLAs, including: <ul style="list-style-type: none"> <li>– Civils and structures.</li> <li>– Associated works such as piping, hydraulics, electrical, instrumentation, and auxiliary systems.</li> </ul>
Piping and valving	<ul style="list-style-type: none"> <li>– All necessary piping and valving.</li> <li>– Odorant injection facilities.</li> <li>– Pig launcher, downstream of the MLAs to tie-in to the natural gas pipeline.</li> </ul>
Gangway	<ul style="list-style-type: none"> <li>– Gangway access tower to provide connection between the wharf and FSRU.</li> </ul>
Utility connections	FSRU utilities connections for: <ul style="list-style-type: none"> <li>– Communications.</li> <li>– Marine Diesel Oil.</li> <li>– Freshwater.</li> <li>– Sewage, bilge, and grey water.</li> </ul>
<b>Utility Area</b>	
Site utilities	Site utilities including: <ul style="list-style-type: none"> <li>– Potable water and sewerage.</li> <li>– Instrument air and bottled nitrogen.</li> <li>– Diesel storage.</li> <li>– Electrical distribution (including UPS and emergency diesel generators).</li> <li>– Control and instrumentation.</li> <li>– Telecommunications.</li> </ul>
<b>Common Areas</b>	
Firefighting systems and equipment	Firefighting equipment including: <ul style="list-style-type: none"> <li>– Firewater storage.</li> <li>– Pumps.</li> <li>– Firewater monitors.</li> </ul>
Security systems and equipment	<ul style="list-style-type: none"> <li>– CCTV.</li> <li>– Fencing and gates.</li> </ul>

Component	Works required
	<ul style="list-style-type: none"> <li>– Security access and monitoring systems.</li> </ul>
Equipment housing	Equipment shelters and buildings to house: <ul style="list-style-type: none"> <li>– Electrical, control, and operating equipment, critical spares, emergency response and site monitoring facilities.</li> <li>– Buildings will include appropriate building services e.g., heating, ventilation and air conditioning, potable water, amenities, sewerage etc.</li> </ul>
Site roadways, lighting and drainage	<ul style="list-style-type: none"> <li>– Roads and car parking areas.</li> <li>– General lighting, earthing, lightning system.</li> <li>– Drainage system to tie into the existing Port Kembla drainage system.</li> </ul>
Gas Pipeline	A section of gas pipeline will be installed within the MBD Compound site as part of the Stage 2A works. Final safety studies will be prepared prior to the construction of the gas pipeline and prior to commencement of operation as per Schedule 3, Condition 21 of Infrastructure Approval (SSI 9471).

## 2.6 Stage 2B: Excavation and dredging

An Emplacement Cell Report (ECR) has been developed by SMEC Australia Pty Ltd (SMEC) titled 'Port Kembla Gas Terminal Development – Emplacement Cell Report' in accordance with Infrastructure Approval (SSI 9471) Schedule 3, Condition 8 and 9. The ECR outlines the design and construction methodology of the Emplacement Cell.

Approximately 450,000 m<sup>3</sup> of materials will be excavated/dredged from the MBD Site Compound and placed within the boundaries of the Emplacement Cell. Further details, including detailed design drawings, can be found in the ECR (SMEC, 2022). A summary of the excavation and dredging works is provided in Section 2.6.2 and Section 2.6.3.

### 2.6.1 Silt curtains

Prior to the commencement of dredging activities, silt curtains will be installed within the Inner Harbour (MBD Site Compound) and Outer Harbour (Emplacement Cell). A fixed gate or bubble curtain gate will be installed to allow for the entrance and exit of barges whilst also controlling the dispersion of silt.

Silt curtains will be suitable for tidal and working harbour conditions.

Navigation and special markers will be installed to the satisfaction of the Harbour Master to alert marine vessels operating in the port harbours of the presence of silt curtains any other risks to navigation.

Further information regarding the use of silt curtains is provided in the Dredge and Excavation Management Plan (DEMP) for Stage 2A and Stage 2B.

### 2.6.2 Excavation and dredge staging

Construction activities undertaken during Stage 1 involved the excavation of fill materials at the MBD Site Compound. Excavation has continued through Stage 2A and will continue as part of Stage 2B. On completion of existing fill materials being excavated, dredging operations will commence at the MBD Site Compound as part of the Stage 2B works.

Dredging activities at the MBD Site Compound and Emplacement Cell will be staged to accommodate other construction works occurring at the MBD Site Compound.

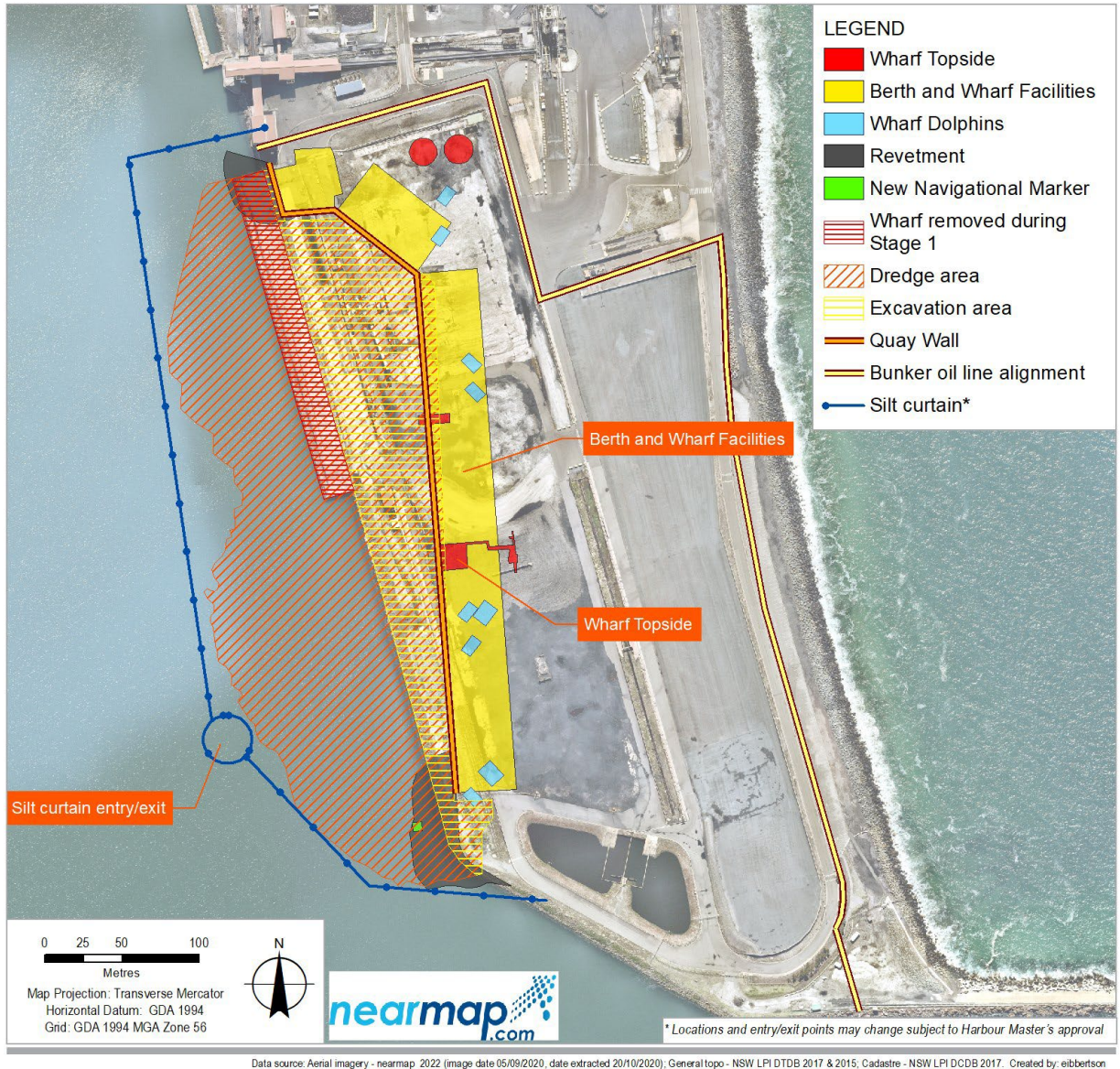
Construction staging for excavation and dredging activities to be undertaken are summarised in the ECR (SMEC, 2022). Excavation and dredging at the MBD Site Compound is shown in Figure 2.6. An overview of the Emplacement Cell is shown in Figure 2.7.

### 2.6.3 Marine-based construction activities at MBD Site Compound

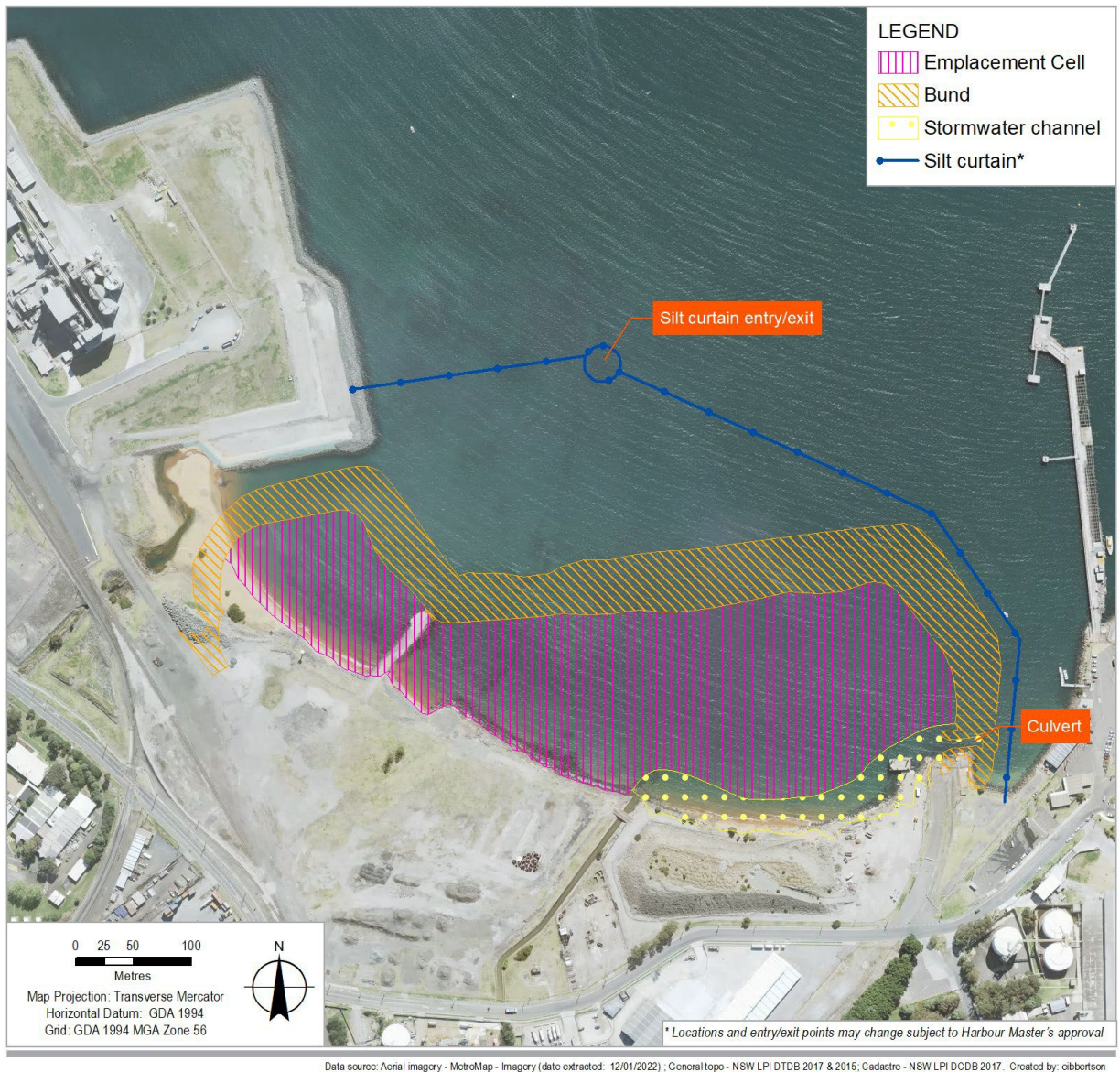
Marine based construction works required at the MBD Site Compound during Stage 2B are summarised in Table 2.5.

Table 2.5 Marine based construction works during Stage 2B

Component	Works required
Navigational aids	<ul style="list-style-type: none"> <li>– Construction of new navigation aid pile through the new southern revetment.</li> <li>– Installation of navigation platform, tower, and lights, including all access requirements such as ladders, platforms, and handrails.</li> <li>– Lights will be battery powered and charged via solar panels.</li> <li>– Existing navigation aid to be removed after the commission of the new navigation aid.</li> </ul>
Revetment shore protection	<ul style="list-style-type: none"> <li>– Revetments will be constructed at the north and south embankments of the new MBD Site Compound wharf (refer to Figure 2.6) following completion of dredging works.</li> <li>– Works will comprise:                             <ul style="list-style-type: none"> <li>• Laydown of Texcel 1200R geotextile.</li> <li>• Placement of thick quarry run to a depth of 190mm.</li> <li>• Placement of underlay rock to a depth of 400mm.</li> <li>• Placement of armour rock to a depth of 900 mm.</li> </ul> </li> </ul>
Revetted Trench	<ul style="list-style-type: none"> <li>– Dredging of an approximate 10x10m trench to -14.5 reduced level (RL) Port Kembla Height Datum (PKHD) for accommodating the under-keel requirements of the FSRU strainers. An approach channel may also be required.</li> <li>– The trench should have sufficient scour protection.</li> </ul>
Berthing box	<ul style="list-style-type: none"> <li>– Dredging will be undertaken to facilitate berthing boxes to be constructed.</li> </ul>



**Figure 2.6** Dredging and excavation works for MBD Site Compound (Stage 2B)



**Figure 2.7** Emplacement Cell overview (Stage 2B)

## 2.7 Stage 2B: Construction of the Emplacement Cell

The Emplacement Cell will be located within the Outer Harbour, comprising of an approximate 800-metre perimeter bund. The Emplacement Cell has been designed and constructed to receive approximately 450,000 m<sup>3</sup> of dredged materials from the MBD Site Compound. Contaminated materials including Harbour Muds (HM)/Harbour Silts (HS) will be placed below -1 m PKHD and at a maximum below LAT (below ~-0.02 m PKHD), and Potential Acid Sulfate Soils (PASS) will be placed below +0.9m PKHD within the Emplacement Cell.

The construction work components and key features of the Emplacement Cell are summarised in Table 2.6. An overview of the Emplacement Cell is shown in Figure 2.7. Further details are provided in the ECR (SMEC, 2022).

Table 2.6 Emplacement Cell key features – Stage 2B

Component	Description
Emplacement Cell	<ul style="list-style-type: none"> <li>– All contaminated soils, including HM/HS and PASS, will be placed within the Emplacement Cell generally below lower than -1.0m PKHD and in no instances above the LAT (~-0.02m PKHD).</li> <li>– The final Emplacement Cell levels will be graded towards the proposed stormwater channel.</li> <li>– Design life of 15 years.</li> </ul>
Perimeter bund	<ul style="list-style-type: none"> <li>– The design bund crest level was derived based on tide, storm surge, sea level rise and wave overtopping and assumed to be +3.55m PKHD. The adopted crest level also includes allowance for assessed post-construction settlement of up to 250mm.</li> <li>– Minimum crest width of 6m and 11m at passing bays.</li> <li>– Maximum permanent batter slopes of 1V:3H for seaward slopes and 1V:2H for landward/internal slopes.</li> <li>– The bund is to accommodate a 110t long reach excavator, fully loaded semi-trailer and temporary material stockpiles.</li> </ul>
Rock revetment	<ul style="list-style-type: none"> <li>– Rock revetment structure will extend to the toe of the main bund to provide protection to the bund structure against coastal processes.</li> </ul>
Stormwater channel	<ul style="list-style-type: none"> <li>– Stormwater channel to extend from the existing Darcy Road drain outlet to the eastern side of the Emplacement Cell.</li> <li>– Stormwater channel outlet is to comprise a box culvert structure on the eastern end of the Emplacement Cell, providing vehicular access onto the bund at the Jetty 3 abutment and within the NSW Ports property boundary.</li> </ul>

### 3. Roles and responsibilities

The Project Team is responsible for all activities associated with Stage 2A and Stage 2B, including the implementation and maintenance of the various mitigation/management measures outlined in this ESCP. Relevant roles and responsibilities of the Project Team are outlined in Table 3.1.

Table 3.1 Roles and responsibilities of Project Team

Project Role	Responsibility
AIE Project Director	<ul style="list-style-type: none"> <li>– Responsible for the overall funding and direction of works associated with Stage 2A and Stage 2B.</li> <li>– Ensuring provision of adequate resources to achieve the environmental objectives for the Project including ensuring sufficient resourcing for the Environmental Team, Engineering and Construction Teams.</li> </ul>
AIE Construction Manager	<ul style="list-style-type: none"> <li>– Proactively stewards the effective implementation of Stage 2A and Stage 2B in accordance with requirements of the Infrastructure Approval (SSI 9471), this ESCP, Environmental Strategy, and all related Sub - plans.</li> <li>– Demonstrate proactive support for environmental requirements.</li> </ul>
AIE HSE Manager	<ul style="list-style-type: none"> <li>– Develop and update all Health, Safety and Environmental (HSE) Management Strategies and Sub - plans.</li> <li>– Ongoing liaison and engagement with government agencies and point of escalation for any environmental incidents.</li> <li>– Identifying environmental issues as they arise and proposing solutions.</li> <li>– Coordinate and facilitate periodic environmental inspections with the key contractors.</li> <li>– Environmental Reporting.</li> </ul>
Emplacement Cell Auditor	<ul style="list-style-type: none"> <li>– Audit the construction of the Emplacement Cell and verify that works have been completed in accordance with the design intent (Emplacement Cell), The auditor role is to satisfy Condition 10 Schedule 3 of the Infrastructure Approval and any other relevant conditions therein.</li> </ul>
Stage 2A Principal Contractor Project Manager and Stage 2B Principal Contractor Project Manager	<ul style="list-style-type: none"> <li>– On-site Project management and control.</li> <li>– Decision-making authority relating to environmental performance of the construction program.</li> <li>– Authority over Project construction and site activities in accordance with the EMS.</li> <li>– Ensure relevant training is provided to all Project staff prior to commencing individual activities.</li> <li>– Reports to AIE Construction Manager on environmental matters.</li> <li>– Ensures appropriate Contractor resources are allocated to implement the environmental requirements.</li> <li>– Responsible for planning and scheduling of construction, and to ensure operations are conducted in accordance with statutory requirements and the EMS.</li> <li>– Monitors performance against environmental Key Performance Indicators (KPI's).</li> <li>– Ensures that all environmental objectives associated with the Project are achieved.</li> <li>– Day-to-day decision-making authority relating to environmental performance of construction activities and direct site activities and construction.</li> <li>– To provide resources to ensure environmental compliance and continuous improvement.</li> <li>– Ensure all personnel are aware of any changes to EMS, this ESCP and improved procedures.</li> <li>– Ensure this ESCP is implemented for the duration of Stage 2A and Stage 2B.</li> </ul>
Stage 2A Principal Contractor Construction Foreman and Stage 2B Principal Contractor Construction Foreman	<ul style="list-style-type: none"> <li>– Implement requirements contained in the EMS and Sub - plans, work procedures and standard drawings.</li> <li>– Maintaining open and transparent communication with other Project discipline managers and other areas of the Project.</li> <li>– Reporting of hazards and incidents and implementing any rectification measures.</li> <li>– Ensures appropriate contractor resources are allocated.</li> </ul>

Project Role	Responsibility
	<ul style="list-style-type: none"> <li>– Orders STOP WORK for any environmental breaches and reports incidents to the Project Manager.</li> <li>– Ensure this ESCP is implemented for the duration of Stage 2A and Stage 2B.</li> </ul>
Stage 2A Principal Contractor Environmental Representative and Stage 2B Principal Contractor Environmental Representative	<ul style="list-style-type: none"> <li>– Delivers environmentally focussed toolbox talks and provides applicable site inductions.</li> <li>– Provides environmental advice, assistance, and direction to Project Manager to ensure construction activities are conducted in accordance with regulatory legislation and this ESCP.</li> <li>– Participate and cooperate with AIE HSE Manager with regards to undertaking of joint environmental site inspections.</li> <li>– Coordinate / undertake wet-weather inspections as per EPL No. 21529 and report accordingly to the AIE HSE Manager.</li> <li>– Develop strong working relationships with the AIE team and Consultants.</li> <li>– Ensure environmental risks are appropriately identified, communicated, and effectively managed.</li> <li>– Ensure communication of relevant environmental information to Project personnel.</li> <li>– Provide specialist advice and input as required.</li> <li>– Ensure construction manager, superintendents and field supervisors fully understand the environmental constraints and how construction practices must ensure any such constraints are considered and mitigated against during construction.</li> <li>– Orders STOP WORK for any environmental breaches and immediately reports incidents to Principal Contractor Project Manager and AIE HSE Manager.</li> </ul>
AIE Environmental Representative and AIE Environmental Contractor	<ul style="list-style-type: none"> <li>– Develop strong working relationships with the Principal Contractor Team and Consultants.</li> <li>– Ensure environmental risks are appropriately identified, communicated, and effectively managed.</li> <li>– Instruct and advise management team on compliance issues.</li> <li>– Provide specialist advice and input as required.</li> <li>– Co-ordinate internal audits of this ESCP.</li> <li>– Conduct audit review as required.</li> <li>– Reports on the performance of this ESCP and recommends changes or improvements to Project Manager.</li> <li>– Orders STOP WORK for any environmental breaches and immediately reports incidents to the AIE Construction Manager and AIE HSE Manager.</li> <li>– Conducts investigation and response to environmental complaints and inquiries, where required.</li> <li>– Undertake all required environmental monitoring for this phase of the Project.</li> </ul>
Subcontractors and construction personnel	<ul style="list-style-type: none"> <li>– Undertake an environmental induction prior to accessing to site.</li> <li>– Comply with legislative requirements.</li> <li>– Participate in inspections and audits.</li> <li>– Follow environmental procedures.</li> <li>– Report all environmental incidents and hazards.</li> <li>– Introduce environmental topics to prestart meetings.</li> <li>– Ensure that all relevant permits and clearances are in place prior to commencing work.</li> </ul>



## 4. Legislative requirements

The legislative requirements applicable to Stage 2A and Stage 2B are listed in Table 4.1.

Table 4.1 *Legislation and relevant policy applicable to this ESCP*

Legislation and Regulation	Description	Applicability
<b>Legislation</b>		
<i>Protection of the Environment Operations Act 1997 (POEO Act)</i>	The objectives of the POEO Act are to protect and enhance the environment of NSW with regard to the need for ecologically sustainable development. The Act provides the statutory framework for managing pollution in NSW, including the procedures for issuing licences for environmental protection on aspects such as waste, air, water, and noise pollution control. It is an offence under Section 120 to pollute any waters.	AIE is committed to ensuring that the Stage 2A and Stage 2B works will not pollute any waters through the implementation of erosion and sediment controls and management. All works will be undertaken in accordance with the issued EPL No. 21529 conditions (refer to Table 5.2).
<b>Planning Instrument</b>		
Wollongong Development Control Plan 2009 (Wollongong DCP)	The Wollongong DCP are a set of policies from Wollongong City Council that detail how developments must be undertaken in order to meet the conditions of the Wollongong Local Environmental Plan 2009 (Wollongong LEP) and State Environmental Planning Policies (SEPPs). The Wollongong LEP does not apply to State significant sites, which includes the Port of Port Kembla.	Chapter 15 of the DCP outlines the objectives for Water Sensitive Urban Design, including controls related to minimisation of stormwater run-off and protect the quality of water run-off from development.  Chapter 22 outlines soil erosion and sediment controls. The objectives are to minimise amount of sediment and contaminated water leaving the site, minimisation of site disturbance and rehabilitation strategies post completion of the works. Control measures outlined in these chapters have been incorporated into this ESCP.
<b>Guidelines</b>		
Managing Urban Stormwater: Soils and Construction – Volume 1 “the Blue Book” (Landcom, 2004).	The Blue Book is a resource guideline which provides management strategies for stormwater and erosion and sediment control during construction of developments.	Management strategies and control measures outlined in the Blue Book have been incorporated into this ESCP.

## **5. Planning requirements**

### **5.1 Conditions of approval**

The planning requirements and the corresponding erosion and sediment control management measures applicable to Stage 2A and Stage 2B are listed in Table 5.1 and Table 5.2. Management measures are detailed in Section 7 and Section 8.

The planning requirements include the conditions set out in the Infrastructure Approval (SSI 9471) dated 13 October 2021, EPL No. 21529 and the mitigation/management measures outlined in the PKGT EIS.

Table 5.1 Planning requirements

Requirement	Reference	Responsibility	Evidence	Applicability to this ESCP
<b>Infrastructure Approval Requirements (SSI 9471)</b>				
<p><b>Soil Erosion</b></p> <p>The Proponent must minimise any soil erosion associated with the construction of the development in accordance with the relevant requirements in the Managing Urban Stormwater: Soils and Construction (Landcom, 2004) manual, or its latest version.</p>	Schedule 3, Condition 5	<ul style="list-style-type: none"> <li>– AIE HSE Manager</li> <li>– AIE Construction Manager</li> <li>– Stage 2A Principal Contractor Construction Foreman and Stage 2B Principal Contractor Construction Foreman</li> </ul>	Section 7.2 Section 8	Applicable
<p><b>Water Pollution</b></p> <p>Unless an environment protection licence authorises otherwise, the Proponent must comply with Section 120 of the POEO Act.</p> <p><i>Notes: Section 120 of the POEO Act makes it an offence to pollute any waters. The EPA has recommended the following limits for water pollutants should apply for the development:</i></p> <ul style="list-style-type: none"> <li>– an equivalent suspended sediment of no more than 50 mg/L above background turbidity levels during the construction stage;</li> </ul> <p><i>No more than 20 ug/L of Total Residual Chlorine and a temperature of no less than 7o C below ambient water temperature for water discharges from the FSRU.</i></p>	Schedule 3, Condition 1	<ul style="list-style-type: none"> <li>– AIE HSE Manager</li> <li>– AIE Construction Manager</li> <li>– Stage 2A Principal Contractor Construction Foreman and Stage 2B Principal Contractor Construction Foreman</li> </ul>	Section 7.2.3 Also refer to Water Quality Monitoring Plan (WQMP)	Applicable
<b>PKGT EIS Management Measures</b>				
<p>A site specific ESCP will be prepared as part of the EMS to provide control of all land based excavation and stockpiling requirements. All erosion and sediment control measures shall be designed, implemented and maintained in accordance with 'Managing Urban Stormwater: Soil and Construction Volume 1' (Landcom 2004) ('the Blue Book).</p>	EIS Measure W10	<ul style="list-style-type: none"> <li>– AIE HSE Manager</li> <li>– AIE Construction Manager</li> <li>– Stage 2A Principal Contractor Construction Foreman and Stage 2B Principal Contractor Construction Foreman</li> </ul>	This ESCP	Applicable
<p>A site specific ESCP will be prepared as part of the EMS. All erosion and sediment control measures shall be designed, implemented and maintained in accordance with relevant sections of 'Managing Urban Stormwater: Soil and Construction Volume 1' (Landcom 2004) ('the Blue Book) (particularly section 2.2) and 'Managing Urban Stormwater: Soil and Construction Volume 2A – Installation of Services' (DECC 2008b). The erosion and sediment control plan will include stockpiles, stormwater runoff, trees, site boundaries, site access and storage areas.</p>	EIS Measure TB6	<ul style="list-style-type: none"> <li>– AIE HSE Manager</li> <li>– AIE Construction Manager</li> <li>– Stage 2A Principal Contractor Construction Foreman and Stage 2B Principal Contractor Construction Foreman</li> </ul>	This ESCP	Applicable
<p>Areas disturbed during the works will be rehabilitated, including stabilising disturbed soils to resist erosion and weed invasion via establishment of with</p>	EIS Measure TB7	<ul style="list-style-type: none"> <li>– AIE HSE Manager</li> </ul>	Section 7.2	Applicable

Requirement	Reference	Responsibility	Evidence	Applicability to this ESCP
<p>a suitable turf species such as a native Couch or repaving roads and sealed surfaces.</p> <p>Stabilisation activities will be carried out progressively to limit the time disturbed areas are exposed to erosion processes</p> <p>Activities with a risk of soil erosion such as earthworks will not be undertaken immediately before or during high rainfall or wind events.</p>		<ul style="list-style-type: none"> <li>- AIE Construction Manager</li> <li>- Stage 2A Principal Contractor Construction Foreman and Stage 2B Principal Contractor Construction Foreman</li> </ul>	<p>Section 8</p> <p>Also refer to Flora and Fauna Management Plan</p>	

## 5.2 Environment Protection Licence

AIE have been issued an EPL under the POEO Act as of 2 June 2021. Conditions applicable to erosion and sediment control management are outlined in Table 5.2.

Table 5.2 EPL No. 21529 conditions

Condition	Reference	Evidence
<p><b>Pollution of waters</b></p> <p>Except as may be expressly provided in any other condition of this licence, the licensee must comply with Section 120 of the POEO Act.</p>	Condition L1.1	Section 7.2.3
<p><b>Processes and management</b></p> <p>The licensee must implement all feasible and reasonable erosion and sediment controls as may be necessary throughout the life of construction works and activities to minimise sediment leaving the premises.</p>	Condition O4.1	Section 7 Section 8
<p>The licensee must ensure erosion and sediment controls are designed (stability, location, type and size), constructed, operated and maintained in accordance with Managing Urban Stormwater – Soils and Construction, Volume 1, 4th Edition (Landcom, 2004).</p> <p>Note: the licensee may consider guidance from other industry best practice documents if it can demonstrate the guidance will provide improved outcomes for the environment and meet the requirements of condition L1.1 of this licence.</p>	Condition O4.2	Section 7
<p>All erosion and sediment control measures on the premises must be inspected and works undertaken to repair and/or maintain these controls:</p> <ol style="list-style-type: none"> <li>weekly during normal construction hours</li> <li>daily during periods of rainfall; and</li> <li>within 24 hours of cessation of a rainfall event causing runoff to occur on or from the premises.</li> </ol> <p>The Licensee must record all such inspections including observations and works undertaken to repair and/or maintain erosion and sediment controls.</p>	Condition O4.4	Section 9
<p>The southern pond in Berth 101 must be maintained to ensure that sedimentation does not reduce their capacity by more than 20% of the design capacity.</p>	Condition O4.5	Section 8

## 6. Existing environment

### 6.1 Topography

The MBD Site Compound is situated between three metres Australian Height Datum (AHD) and five metres AHD. The MBD Site Compound gently slopes from south to west with a large, constructed settlement pond present within the southern portion of the site (the Southern Pond). The Project will be situated on largely reclaimed land that has historically been highly disturbed and subject to industrial land uses.

The Emplacement Cell Construction site is located in a highly modified and industrial setting. The site is generally flat and sits at elevations between three metres and ten metres AHD. The Emplacement Cell Construction site is adjacent to the Outer Harbour and bounded by a rail corridor, roads and industrial sites. The site has been largely cleared of all vegetation and is currently used for stockpiling.

### 6.2 Soils and geology

A desktop review of the Australian Soil Resource Information System (ASRIS) (ASRIS, 2011) shows that dermosols are mapped as the predominant soil type within the MBD Site Compound. The original soil within the MBD Site Compound has been removed, greatly disturbed or buried. Site investigations undertaken by Worley Parsons (2012) and summarised by GHD (2018) showed that fill materials encountered generally contained coal, coal wash and slag with trace fragments of asbestos containing materials and other anthropogenic materials.

The Wollongong-Port Hacking 1:100 000 Soil Landscape Series Sheet 9029-9129 (Soil Conservation Service of NSW, 1990) indicates the Emplacement Cell Construction Site is located within a disturbed terrain soil landscape which has been disturbed by human activity with the original soils being removed, greatly disturbed or buried. Geological mapping indicates the site comprises of Quaternary sediments described as quartz and lithic fluvial sand, silt, and clay (Geological Survey of NSW, 1985).

### 6.3 Acid Sulfate Soils (ASS)

GHD (2018a) have identified the presence of ASS at the MBD Site Compound. ASS was found to occur in natural sediments below the fill (variable and to depths between 2.5 and 5.5 metres below ground level (mbgl) to at least 14 metres depth and likely beyond, particularly where dark grey and green clays exist. Estuarine sediments exist within the harbour and are mapped as high probability of ASS.

The Emplacement Cell Construction Site is not located in an area mapped as being at ASS risk on the ASS risk map (DLWC, 1997).

The design of the Emplacement Cell indicates that all ASS and contaminated materials can be placed below +0.9m PKHD (SMEC, 2022). In the event that there are excess materials of ASS that cannot be placed in the Emplacement Cell, offshore and onshore disposal may be required. This is currently being investigated by AIE and would be subject to approval by relevant authorities such as DP&E. Neutralisation/treatment options have been disregarded due to the difficulty of applying these measures to stiff clays. Additional information on ASS is provided in the Stage 2A and Stage 2B Acid Sulfate Soils Management Plan (ASSMP).

### 6.4 Contaminated soils

A high-level assessment for contamination was undertaken for the Project and included within the PKGT Submissions Report (GHD, 2019). Whilst no widespread or gross contamination was found, there is considered to be a moderate potential for contamination based upon the nature of the fill material and potentially contaminating activities from surrounding industry at the MBD Site Compound (GHD, 2019). Further detail regarding potential/known contamination that may be encountered during Stage 2A and Stage 2B, and associated controls, is contained within the SMP, ASSMP and Contaminated Spoil Protocol (CSP).

## 6.5 Climate

Climate statistics were obtained from the Bureau of Meteorology (BOM) for Port Kembla Signal Station (068053). Average rainfall (millimetres) data for Port Kembla Signal Station (068053) (BOM, 2019) is shown in Table 6.1 and Figure 6.1. The figures show an increased average rainfall during the spring months; however, significant rainfall can occur at any time during the year.

Table 6.1 Average rainfall (mm) data for Port Kembla Signal Station (068053) (BOM, 2019)

	Jan	Feb	Mar	Apr	May	Jun	Jul	Aug	Sep	Oct	Nov	Dec	Total
Mean Rainfall (mm)	116.1	157.5	183.7	92.9	89	140.3	62.6	87.7	55	108	94.3	90.4	1260.6

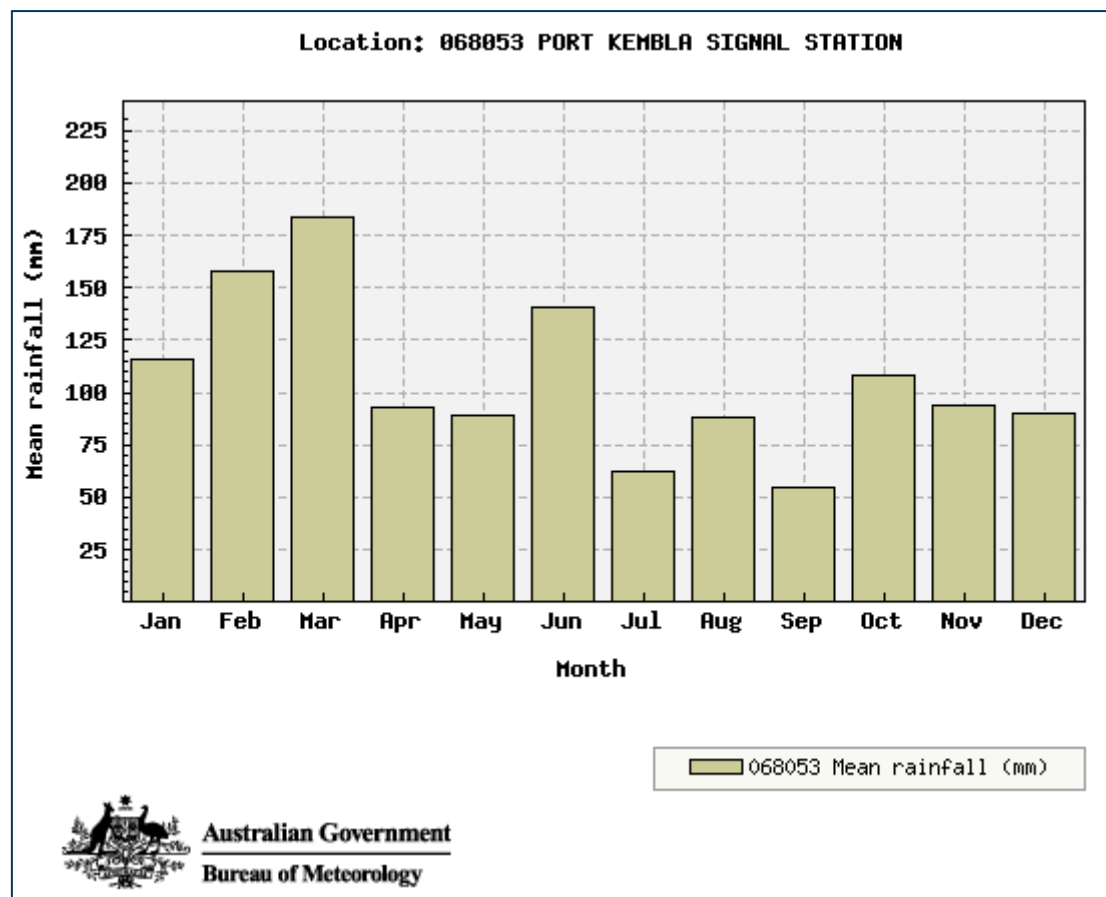


Figure 6.1 Average rainfall (mm) graph for Port Kembla Signal Station (068053) (BOM, 2019)

# 7. Progressive Erosion and Sediment Control Plans

## 7.1 Development of PESCPs

PESCPs will be developed for high-risk areas prior to commencing work. PESCPs are site-specific plans that sit under this overarching ESCP. PESCPs will include, at a minimum:

- A drawing or marked up map showing the layout and details of erosion and sediment control measures including runoff, stockpiles, site access and storage areas.
- Supporting site specific commentary or construction notes containing explanatory text, calculations, and diagrams, as necessary.
- Calculations and sizing of controls, as required.

The preparation of PESCPs will utilise the design criteria and standards stipulated in Section 7.2. The Principal Contractors will be responsible for developing the plans with sign-off by a Certified Professional in Erosion and Sediment Control (CPESC). All erosion and sediment control devices will be designed to minimise any soil erosion associated with the construction of Stage 2A and Stage 2B works, in accordance with the relevant requirements in the *Managing Urban Stormwater: Soils and Construction* (Landcom, 2004) manual, or its latest version.

PESCPs are to be maintained to ensure they accurately reflect the construction works occurring on site. All feasible and reasonable erosion and sediment controls as may be necessary will be implemented throughout the life of construction works and activities to minimise sediment leaving the premises.

## 7.2 Design criteria

### 7.2.1 Erosion hazard (RUSLE)

An indicative erosion hazard assessment using the Revised Universal Soil Loss Equation (RUSLE) equation has been undertaken for the Project area and should be updated using site-specific soils data for the PESCPs.

$$A = R \cdot K \cdot LS \cdot C \cdot P$$

Table 7.1 details the factors and adopted values for the assessment.

Table 7.1 RUSLE factors

RUSLE Parameter	Description	Adopted Value
R-Factor	Rainfall erosivity	4,421 based on $R = 164.74 (1.1177)^S S^{0.6444}$ where S equals the 2yr-6hr storm (14.2 mm)
K-Factor	Soil erodibility factor	0.04 based on a conservative silty clay loam estimate
LS-Factor	Topographic factor	Variable based on site specific conditions
P-Factor	Soil conservation practice factor	Default of 1.3 to be used (smooth and compacted)
C-factor	Ground cover factor	Default of 1.0 to be used (no ground cover)

Table 7.2 details the estimated Soil Loss Class (SLC) and equivalent soil loss rate (tonnes / hectares / year) for a range of slopes and lengths across the MBD Site Compound. The estimated SLC for the Project is SLC 1 with a soil loss rate of approximately 149 tonnes / hectares / year. Type 2 and 3 controls will typically be installed across the MBD Site Compound including diversion banks, sediment traps and filter tubes, as discussed in the following sections and in Appendix A.

Monthly erosion risk and hazards will be taken into consideration during the development of PESCPs.



Table 7.2 Erosion risk and annual soil loss for the Project

% Grade	Slope Lengths											Soil Loss Class	
	100	90	80	70	60	50	40	30	20	10	5		
10	752	699	646	589	531	469	402	331	251	156	97	1	0 to 150
9	631	589	544	497	449	397	343	283	216	136	86	2	151 to
8	545	508	471	432	391	347	301	248	191	122	78	3/4	226 to
7	465	435	404	372	337	301	261	218	169	109	71	5/6	501 to
6	386	363	338	313	285	255	223	186	147	97	64	7	> 1,500
5	310	292	274	253	232	209	184	156	124	83	55		
4	237	223	209	195	179	163	145	124	101	69	48		
3	166	159	149	140	131	120	108	94	78	55	39		
2	101	99	94	90	83	78	71	64	55	41	32		
1	46	46	44	44	41	39	37	34	30	25	21		

## 7.2.2 Minimum design standards

The minimum design storm standard for temporary sediment and erosion controls with a design life up to six months are summarised in Table 7.3.

Table 7.3 Minimum design standards (DECC, 2008)

Control Measure	Minimum Design Storm Event – average recurrence interval (ARI)	
	Standard Design	Sensitive Environment
<b>Temporary Drainage (Erosion) Controls</b>		
(e.g., diversion banks, catch drains, level spreaders, check dams) should be designed to have a non-erosive hydraulic capacity (excluding freeboard) sufficient to convey the nominated design storm event.	2-year ARI	5-year ARI
<b>Temporary Sediment Controls</b>		
(e.g., sediment fences, stacked rock sediment traps) in small catchments, where used as a 'last line of defence', should be constructed to remain structurally sound in the nominated design storm event.	2-year ARI	5-year ARI
<b>Type D/F Sediment Retention Basins (if required)</b>		
Basin volume based on nominated percentile rainfall depth for 5-day duration storm.	75th percentile	80th percentile
Embankment and spillway.	10-year ARI	20-year ARI

## 7.2.3 Standard PKGT controls

A PESCP will be developed for the PKGT prior to commencing works. The PESCP is to prioritise the installation of final design stormwater structures and utilise the existing PKGT settling pond located on the southern boundary of the works, if possible. The PESCP will be reviewed and approved by a CPESC. The Project will comply with Section 120 of the POEO Act by not polluting the harbour, which includes ensuring Total Suspended Solids level of construction discharge is no more than 50mg/L using a water treatment system. Mitigation measures to ensure the Project complies with Section 120 of the POEO Act can be found in the Stage 2A and Stage 2B WQMP.

## 7.2.4 Standard pipeline controls

Appendix P of the International Erosion Control Association (IECA) provides detail on pipeline alignment controls. Table 7.4, taken from (IECA, 2008), details the typical controls and considerations associated with management erosion and sediment control on pipeline projects.

Table 7.4 Typical ESC practices for pipelines (IECA, 2008)

Category	Key tasks
Drainage control	<ul style="list-style-type: none"> <li>• Diversion of 'clean' up-slope run-on water either around or through the construction site.</li> <li>• Collection of 'dirty' runoff generated within the RoW and the delivery of this water to an appropriate sediment trap.</li> <li>• Minimising the risk of soil erosion caused by site-generated flows passing along the RoW through the use of 'intermediate' flow treatment and release points.</li> <li>• Control of the flow velocity of water passing through the RoW at drainage line and waterway crossings.</li> </ul>
Erosion control	<ul style="list-style-type: none"> <li>• Appropriate management of work programming and the scheduling of forward works with the aim of minimising the erosion risk.</li> <li>• Control soil erosion at drainage line and waterway crossings caused by run-on water passing through (across) the RoW (this task is closely linked to the 'drainage control' task listed above).</li> <li>• Control of soil erosion at vehicle crossings of drainage line and waterway crossings</li> <li>• Minimising the extent of vegetation and soil disturbance at drainage line and waterway crossings.</li> <li>• Erosion control practices during site rehabilitation.</li> </ul>
Sediment control	<ul style="list-style-type: none"> <li>• Treatment of 'dirty' water runoff generated within the RoW.</li> <li>• Sediment control at vehicle exit points from the pipeline RoW.</li> <li>• Integration of sediment control attributes into the drainage/erosion control practices installed at drainage line and waterway crossings.</li> </ul>

Figure 7.1, Figure 7.2 and Figure 7.3 provide guidance, but not exhaustive, on right of way (RoW) erosion and sediment control set up to be directed by the Principal Contractors on site on low to moderate risk erosion areas.

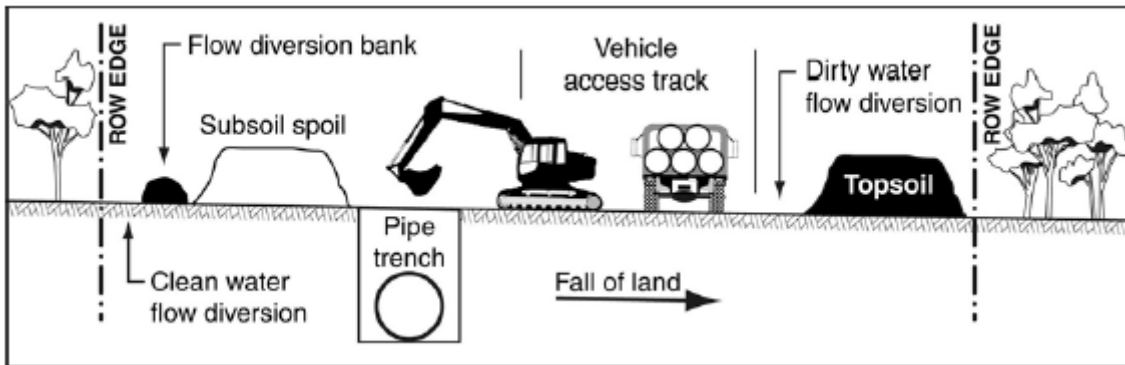


Figure 7.1 Typical ROW trench up slope of vehicle access track (IECA, 2008)

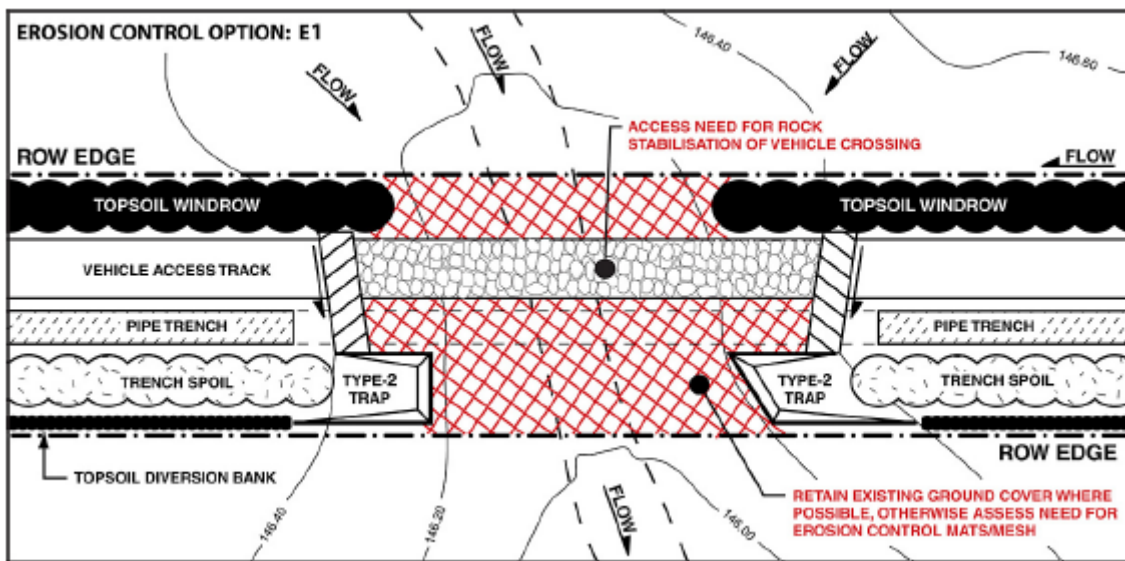


Figure 7.2 Typical layout of erosion controls Option E1 (IECA, 2008)

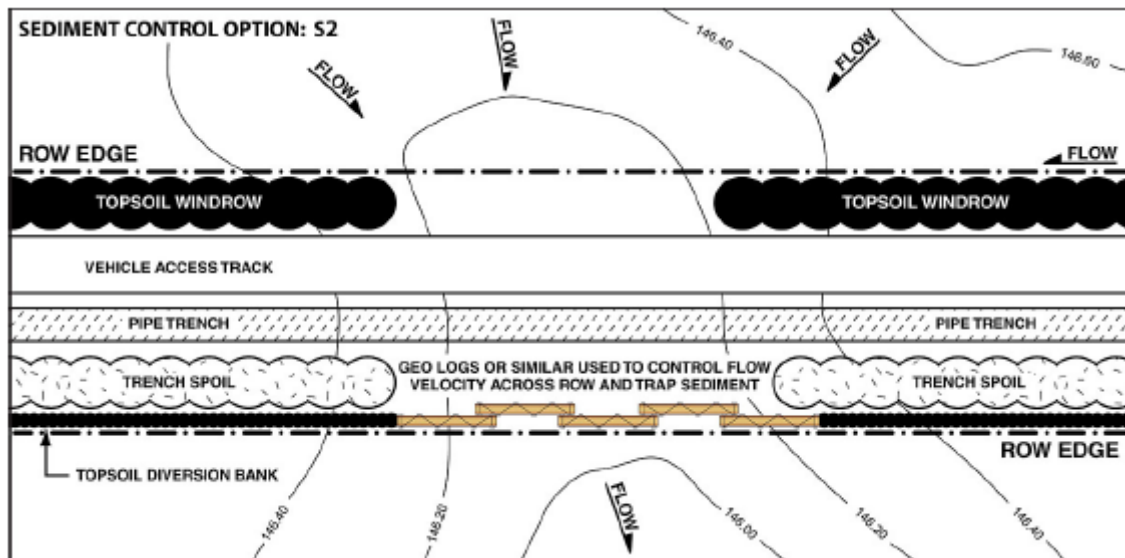


Figure 7.3 Sediment control option S2 (IECA, 2008)

## 8. Management and mitigation measures

Mitigation and management measures to eliminate or otherwise reduce the risk of erosion and sedimentation during Stage 2A and Stage 2B construction works are outlined in Table 8.1.

Table 8.1 Mitigation/management measures for erosion and sedimentation during Stage 2A and Stage 2B

Measure/ Requirement	Timing	Responsibility	Evidence
<b>General</b>			
PESCPs will be developed for high-risk areas prior to commencing works.	Preconstruction	<ul style="list-style-type: none"> <li>– AIE Environmental Rep</li> <li>– Stage 2A Principal Contractor Environmental Rep and Stage 2B Principal Contractor Environmental Rep</li> </ul>	PESCPs
A register of PESCPs will be maintained in the Project office along with copies of PESCPs.	During construction	<ul style="list-style-type: none"> <li>– AIE Environmental Rep</li> <li>– Stage 2A Principal Contractor Environmental Rep and Stage 2B Principal Contractor Environmental Rep</li> </ul>	Register
PESCPs will be prepared using the design criteria detailed in Section 7.2 of this plan unless site specific conditions justify alternative values.	Preconstruction	<ul style="list-style-type: none"> <li>– AIE Environmental Rep</li> <li>– Stage 2A Principal Contractor Environmental Rep and Stage 2B Principal Contractor Environmental Rep</li> </ul>	PESCPs
The Stage 2A and Stage 2B Principal Contractor Environmental Representatives and Construction Foremen will monitor weather conditions and forecasts daily and plan works activities in accordance with risk including stabilisation of site as required.	During construction	<ul style="list-style-type: none"> <li>– AIE Environmental Rep</li> <li>– Stage 2A Principal Contractor Environmental Rep and Stage 2B Principal Contractor Environmental Rep</li> <li>– Stage 2A Principal Contractor Construction Foreman and Stage 2B Principal Contractor Construction Foreman</li> </ul>	Daily prestart
Relevant documentation and systems for recording environmental activities will be implemented including: <ul style="list-style-type: none"> <li>– Inspection checklist</li> <li>– Water quality monitoring (as per the WQMP)</li> <li>– Contaminated Land/ASS registers.</li> </ul>	During construction	<ul style="list-style-type: none"> <li>– AIE Environmental Rep</li> <li>– Stage 2A Principal Contractor Environmental Rep and Stage 2B Principal Contractor Environmental Rep</li> <li>– Site Engineers</li> </ul>	<ul style="list-style-type: none"> <li>– Checklist</li> <li>– Monitoring records</li> <li>– Register</li> </ul>
Key erosion and sediment control measures such as sediment traps and clean water diversions will be installed as early works, where practicable.	During construction	<ul style="list-style-type: none"> <li>– AIE Environmental Rep</li> <li>– Stage 2A Principal Contractor Environmental Rep and Stage 2B Principal Contractor Environmental Rep</li> <li>– Stage 2A Principal Contractor Construction Foreman and Stage 2B Principal Contractor Construction Foreman</li> </ul>	Inspection checklist
Adequate supplies of erosion and sediment control materials will be available on site at all times.	During construction	<ul style="list-style-type: none"> <li>– Stage 2A Principal Contractor Project Manager and Stage 2B Principal Contractor Project Manager</li> <li>– AIE Environmental Rep</li> <li>– Stage 2A Principal Contractor Environmental Rep and Stage 2B</li> </ul>	Inspection checklist

Measure/ Requirement	Timing	Responsibility	Evidence
		Principal Contractor Environmental Rep	
High risk works such as earthworks, will not be undertaken immediately before or during high rainfall or wind events.	During construction	<ul style="list-style-type: none"> <li>– Stage 2A Principal Contractor Project Manager and Stage 2B Principal Contractor Project Manager</li> <li>– AIE Environmental Rep</li> <li>– Stage 2A Principal Contractor Environmental Rep and Stage 2B Principal Contractor Environmental Rep</li> </ul>	Inspection checklist
Environmental incidents will be reported in accordance with Section 9 of the EMS.	During construction	<ul style="list-style-type: none"> <li>– Stage 2A Principal Contractor Project Manager and Stage 2B Principal Contractor Project Manager</li> <li>– AIE Environmental Rep</li> <li>– Stage 2A Principal Contractor Environmental Rep and Stage 2B Principal Contractor Environmental Rep</li> </ul>	Incident report
<b>Training</b>			
Erosion and sediment control aspects will be included in the site induction for the Project.	Preconstruction	<ul style="list-style-type: none"> <li>– Stage 2A Principal Contractor Project Manager and Stage 2B Principal Contractor Project Manager</li> <li>– AIE Environmental Rep</li> <li>– Stage 2A Principal Contractor Environmental Rep and Stage 2B Principal Contractor Environmental Rep</li> </ul>	Induction records
Erosion and sediment control training will be regularly provided to Project staff as required including de-watering and correct installation of controls.	During construction	<ul style="list-style-type: none"> <li>– AIE Environmental Rep</li> <li>– Stage 2A Principal Contractor Environmental Rep and Stage 2B Principal Contractor Environmental Rep</li> </ul>	Toolbox records
<b>Erosion control</b>			
Disturbance will be staged and limited to the least amount practicable to undertake the upcoming works safely.	During construction	<ul style="list-style-type: none"> <li>– Stage 2A Principal Contractor Project Manager and Stage 2B Principal Contractor Project Manager</li> <li>– AIE Environmental Rep</li> <li>– Stage 2A Principal Contractor Environmental Rep and Stage 2B Principal Contractor Environmental Rep</li> <li>– Stage 2A Principal Contractor Construction Foreman and Stage 2B Principal Contractor Construction Foreman</li> </ul>	Inspection checklist
Temporary ground covers (i.e., geofabric, soil binder) will be utilised to provide temporary cover prior to rainfall as appropriate or in areas where sediment controls are unable to be installed.	During construction	<ul style="list-style-type: none"> <li>– AIE Environmental Rep</li> <li>– Stage 2A Principal Contractor Environmental Rep and Stage 2B Principal Contractor Environmental Rep</li> <li>– Stage 2A Principal Contractor Construction Foreman and Stage 2B Principal Contractor Construction Foreman</li> </ul>	PESCPs
Construction works will be planned and staged to allow for timely and progressive stabilisation and rehabilitation of completed areas. Interim surface stabilisation	During construction	<ul style="list-style-type: none"> <li>– AIE Environmental Rep</li> <li>– Stage 2A Principal Contractor Environmental Rep and Stage 2B</li> </ul>	PESCPs

Measure/ Requirement	Timing	Responsibility	Evidence
measures, e.g. bucket compaction and polymer/binder, will be utilised progressively throughout the Project, prior to final project surface specification (e.g. hardstand).		Principal Contractor Environmental Rep – Stage 2A Principal Contractor Construction Foreman and Stage 2B Principal Contractor Construction Foreman	
<b>Sediment control</b>			
Sediment controls are to be installed to capture or treat dirty water prior to discharge off site.	During construction	– AIE Environmental Rep – Stage 2A Principal Contractor Environmental Rep and Stage 2B Principal Contractor Environmental Rep – Stage 2A Principal Contractor Construction Foreman and Stage 2B Principal Contractor Construction Foreman	– PESCPs – Inspection checklist
Sediment controls requiring excavations will be avoided in known areas of ASS/ PASS. Erosion controls will be utilised.	During construction	– AIE Environmental Rep – Stage 2A Principal Contractor Environmental Rep and Stage 2B Principal Contractor Environmental Rep – Stage 2A Principal Contractor Construction Foreman and Stage 2B Principal Contractor Construction Foreman	PESCPs
Sediment controls are to remain in place until appropriate stabilisation of the catchment is undertaken or are no longer required.	During construction	– AIE Environmental Rep – Stage 2A Principal Contractor Environmental Rep and Stage 2B Principal Contractor Environmental Rep – Stage 2A Principal Contractor Construction Foreman and Stage 2B Principal Contractor Construction Foreman	Inspection checklist
Coagulants or flocculants will be used, where appropriate, to control turbidity levels and to improve the effectiveness of Type 2 and 3 controls.	During construction	– AIE Environmental Rep – Stage 2A Principal Contractor Environmental Rep and Stage 2B Principal Contractor Environmental Rep – Stage 2A Principal Contractor Construction Foreman and Stage 2B Principal Contractor Construction Foreman	Permit to Discharge
<b>Access and maintenance</b>			
All vehicles leaving site are to ensure vehicle is free of excess sediment.	During construction	– AIE Environmental Rep – Stage 2A Principal Contractor Environmental Rep and Stage 2B Principal Contractor Environmental Rep – Stage 2A Principal Contractor Construction Foreman and Stage 2B Principal Contractor Construction Foreman	Inspection checklist
Stabilised access points will be installed, where required, typically from unsealed work areas to public roads.	During construction	– AIE Environmental Rep – Stage 2A Principal Contractor Environmental Rep and Stage 2B Principal Contractor Environmental Rep	Inspection checklist

Measure/ Requirement	Timing	Responsibility	Evidence
		<ul style="list-style-type: none"> <li>– Stage 2A Principal Contractor Construction Foreman and Stage 2B Principal Contractor Construction Foreman</li> </ul>	
Street sweepers and other methods are to be deployed to clean up excess sediment tracked onto roads.	During construction	<ul style="list-style-type: none"> <li>– AIE Environmental Rep</li> <li>– Stage 2A Principal Contractor Environmental Rep and Stage 2B Principal Contractor Environmental Rep</li> <li>– Stage 2A Principal Contractor Construction Foreman and Stage 2B Principal Contractor Construction Foreman</li> </ul>	Inspection checklist
Material deliveries are to have covered loads.	During construction	<ul style="list-style-type: none"> <li>– AIE Environmental Rep</li> <li>– Stage 2A Principal Contractor Environmental Rep and Stage 2B Principal Contractor Environmental Rep</li> <li>– Stage 2A Principal Contractor Construction Foreman and Stage 2B Principal Contractor Construction Foreman</li> </ul>	Inspection checklist
Access to site is to be restricted during and post rainfall if required to prevent excess sediment tracking.	During construction	<ul style="list-style-type: none"> <li>– AIE Environmental Rep</li> <li>– Stage 2A Principal Contractor Environmental Rep and Stage 2B Principal Contractor Environmental Rep</li> <li>– Stage 2A Principal Contractor Construction Foreman and Stage 2B Principal Contractor Construction Foreman</li> </ul>	Inspection checklist
<b>Drainage control</b>			
'Clean' water runoff is to be diverted around or through site and 'dirty' water is to be captured or treated prior to exiting works areas.	During construction	<ul style="list-style-type: none"> <li>– AIE Environmental Rep</li> <li>– Stage 2A Principal Contractor Environmental Rep and Stage 2B Principal Contractor Environmental Rep</li> <li>– Stage 2A Principal Contractor Construction Foreman and Stage 2B Principal Contractor Construction Foreman</li> </ul>	PESCPs
Areas subject to concentrated flow (i.e., diversion drains, batter chutes) are to be lined with geofabric, seed, erosion control matting or similar to minimise erosion.	During construction	<ul style="list-style-type: none"> <li>– AIE Environmental Rep</li> <li>– Stage 2A Principal Contractor Environmental Rep and Stage 2B Principal Contractor Environmental Rep</li> <li>– Stage 2A Principal Contractor Construction Foreman and Stage 2B Principal Contractor Construction Foreman</li> </ul>	PESCPs
Outlets of pipes or culverts are to have energy dissipaters installed (i.e., scour rock).	During construction	<ul style="list-style-type: none"> <li>– AIE Environmental Rep</li> <li>– Stage 2A Principal Contractor Environmental Rep and Stage 2B Principal Contractor Environmental Rep</li> <li>– Stage 2A Principal Contractor Construction Foreman and Stage 2B Principal Contractor Construction Foreman</li> </ul>	PESCPs / design drawings

Measure/ Requirement	Timing	Responsibility	Evidence
Check dams may be installed in drainage as velocity checks. Placement of rock on dispersive soils should be avoided.	During construction	<ul style="list-style-type: none"> <li>– AIE Environmental Rep</li> <li>– Stage 2A Principal Contractor Environmental Rep and Stage 2B Principal Contractor Environmental Rep</li> <li>– Stage 2A Principal Contractor Construction Foreman and Stage 2B Principal Contractor Construction Foreman</li> </ul>	PESCPs
Slope lengths in areas of exposed soils will be limited to a maximum of 80 m whenever inclement weather is forecast.	During construction	<ul style="list-style-type: none"> <li>– AIE Environmental Rep</li> <li>– Stage 2A Principal Contractor Environmental Rep and Stage 2B Principal Contractor Environmental Rep</li> <li>– Stage 2A Principal Contractor Construction Foreman and Stage 2B Principal Contractor Construction Foreman</li> </ul>	Inspection checklist
The southern pond within the MBD Site Compound must be maintained to ensure that sedimentation does not reduce their capacity by more than 20% of the design capacity.	During construction	<ul style="list-style-type: none"> <li>– AIE Environmental Rep</li> <li>– Stage 2A Principal Contractor Environmental Rep and Stage 2B Principal Contractor Environmental Rep</li> <li>– Stage 2A Principal Contractor Construction Foreman and Stage 2B Principal Contractor Construction Foreman</li> </ul>	Inspection checklist
<b>Stockpile management</b>			
Stockpiles of materials will be positioned in appropriate locations as far away from the marine environment and drainage lines as reasonably practicable.	During construction	<ul style="list-style-type: none"> <li>– AIE Environmental Rep</li> <li>– Stage 2A Principal Contractor Environmental Rep and Stage 2B Principal Contractor Environmental Rep</li> <li>– Stage 2A Principal Contractor Construction Foreman and Stage 2B Principal Contractor Construction Foreman</li> </ul>	Inspection checklist
Materials are to be stockpiled separately wherever practicable.	During construction	<ul style="list-style-type: none"> <li>– AIE Environmental Rep</li> <li>– Stage 2A Principal Contractor Environmental Rep and Stage 2B Principal Contractor Environmental Rep</li> <li>– Stage 2A Principal Contractor Construction Foreman and Stage 2B Principal Contractor Construction Foreman</li> </ul>	Inspection checklist
ASS and contaminated land are to be managed and stockpiled in accordance with the Projects ASSMP and CSP.	During construction	<ul style="list-style-type: none"> <li>– AIE Environmental Rep</li> <li>– Stage 2A Principal Contractor Environmental Rep and Stage 2B Principal Contractor Environmental Rep</li> <li>– Stage 2A Principal Contractor Construction Foreman and Stage 2B Principal Contractor Construction Foreman</li> </ul>	Inspection checklist
Inactive stockpiles will be stabilised to a C-factor of 0.15 (equivalent ground cover of about 50%) within 20 working days of inactivity.	During construction	<ul style="list-style-type: none"> <li>– AIE Environmental Rep</li> <li>– Stage 2A Principal Contractor Environmental Rep and Stage 2B</li> </ul>	Inspection checklist



Measure/ Requirement	Timing	Responsibility	Evidence
		Principal Contractor Environmental Rep – Stage 2A Principal Contractor Construction Foreman and Stage 2B Principal Contractor Construction Foreman	
Stockpiles should be maintained at heights less than 10 m, where practicable.	During construction	– AIE Environmental Rep – Stage 2A Principal Contractor Environmental Rep and Stage 2B Principal Contractor Environmental Rep – Stage 2A Principal Contractor Construction Foreman and Stage 2B Principal Contractor Construction Foreman	Inspection checklist
Stockpiles are to be battered to no steeper than 2:1 (H:V).	During construction	– AIE Environmental Rep – Stage 2A Principal Contractor Environmental Rep and Stage 2B Principal Contractor Environmental Rep – Stage 2A Principal Contractor Construction Foreman and Stage 2B Principal Contractor Construction Foreman	Inspection checklist
Dust suppression will be undertaken, as required, on stockpiles.	During construction	– AIE Environmental Rep – Stage 2A Principal Contractor Environmental Rep and Stage 2B Principal Contractor Environmental Rep – Stage 2A Principal Contractor Construction Foreman and Stage 2B Principal Contractor Construction Foreman	Inspection checklist
<b>Dust suppression</b>			
Dust suppression will be undertaken when necessary to minimise airborne dust.	During construction	– AIE Environmental Rep – Stage 2A Principal Contractor Environmental Rep and Stage 2B Principal Contractor Environmental Rep – Stage 2A Principal Contractor Construction Foreman and Stage 2B Principal Contractor Construction Foreman	Inspection checklist
Where possible, utilise retained water on site as priority.	During construction	– AIE Environmental Rep – Stage 2A Principal Contractor Environmental Rep and Stage 2B Principal Contractor Environmental Rep – Stage 2A Principal Contractor Construction Foreman and Stage 2B Principal Contractor Construction Foreman	Inspection checklist
Cover dust-creating loads while in transit on public roads.	During construction	– AIE Environmental Rep – Stage 2A Principal Contractor Environmental Rep and Stage 2B Principal Contractor Environmental Rep – Stage 2A Principal Contractor Construction Foreman and Stage 2B	Inspection checklist

Measure/ Requirement	Timing	Responsibility	Evidence
		Principal Contractor Construction Foreman	
Monitor weather forecasts for conditions that will cause excessive dust generation and plan works accordingly.	During construction	<ul style="list-style-type: none"> <li>– AIE Environmental Rep</li> <li>– Stage 2A Principal Contractor Environmental Rep and Stage 2B Principal Contractor Environmental Rep</li> <li>– Stage 2A Principal Contractor Construction Foreman and Stage 2B Principal Contractor Construction Foreman</li> </ul>	Daily prestart
Apply soil binder to haul roads and exposed areas such as laydowns if required.	During construction	<ul style="list-style-type: none"> <li>– AIE Environmental Rep</li> <li>– Stage 2A Principal Contractor Environmental Rep and Stage 2B Principal Contractor Environmental Rep</li> <li>– Stage 2A Principal Contractor Construction Foreman and Stage 2B Principal Contractor Construction Foreman</li> </ul>	Inspection checklist
<b>Clear and grade</b>			
Disturbance areas will be clearly delineated and established prior to commencing clear and grade activities.	Pre-construction	<ul style="list-style-type: none"> <li>– AIE Environmental Rep</li> <li>– Stage 2A Principal Contractor Environmental Rep and Stage 2B Principal Contractor Environmental Rep</li> <li>– Stage 2A Principal Contractor Construction Foreman and Stage 2B Principal Contractor Construction Foreman</li> </ul>	Daily prestart
Erosion and sediment control measures are to be installed prior to stripping or immediately following for each discrete works area.	During construction	<ul style="list-style-type: none"> <li>– AIE Environmental Rep</li> <li>– Stage 2A Principal Contractor Environmental Rep and Stage 2B Principal Contractor Environmental Rep</li> <li>– Stage 2A Principal Contractor Construction Foreman and Stage 2B Principal Contractor Construction Foreman</li> </ul>	Inspection checklist
All vegetation that is to be maintained is to be clearly marked.	Pre-construction	<ul style="list-style-type: none"> <li>– AIE Environmental Rep</li> <li>– Stage 2A Principal Contractor Environmental Rep and Stage 2B Principal Contractor Environmental Rep</li> <li>– Stage 2A Principal Contractor Construction Foreman and Stage 2B Principal Contractor Construction Foreman</li> </ul>	Pre-clearance Survey
Land clearing is to be undertaken progressively and limited to only that which is necessary for upcoming works.	During construction	<ul style="list-style-type: none"> <li>– AIE Environmental Rep</li> <li>– Stage 2A Principal Contractor Environmental Rep and Stage 2B Principal Contractor Environmental Rep</li> <li>– Stage 2A Principal Contractor Construction Foreman and Stage 2B Principal Contractor Construction Foreman</li> </ul>	Inspection checklist
<b>Trenching</b>			

Measure/ Requirement	Timing	Responsibility	Evidence
Avoid trenching in areas where water flow is likely to concentrate or schedule works for dry periods, where feasible.	During construction	<ul style="list-style-type: none"> <li>– AIE Environmental Rep</li> <li>– Stage 2A Principal Contractor Environmental Rep and Stage 2B Principal Contractor Environmental Rep</li> <li>– Stage 2A Principal Contractor Construction Foreman and Stage 2B Principal Contractor Construction Foreman</li> </ul>	Daily prestart
Ensure trench widths and depths are the minimum necessary.	During construction	<ul style="list-style-type: none"> <li>– AIE Environmental Rep</li> <li>– Stage 2A Principal Contractor Environmental Rep and Stage 2B Principal Contractor Environmental Rep</li> <li>– Stage 2A Principal Contractor Construction Foreman and Stage 2B Principal Contractor Construction Foreman</li> </ul>	Design
Ensure trench spoil and topsoils are stockpiled separately and avoid mixing.	During construction	<ul style="list-style-type: none"> <li>– AIE Environmental Rep</li> <li>– Stage 2A Principal Contractor Environmental Rep and Stage 2B Principal Contractor Environmental Rep</li> <li>– Stage 2A Principal Contractor Construction Foreman and Stage 2B Principal Contractor Construction Foreman</li> </ul>	Inspection checklist
Divert surface water away from trench openings, where feasible.	During construction	<ul style="list-style-type: none"> <li>– AIE Environmental Rep</li> <li>– Stage 2A Principal Contractor Environmental Rep and Stage 2B Principal Contractor Environmental Rep</li> <li>– Stage 2A Principal Contractor Construction Foreman and Stage 2B Principal Contractor Construction Foreman</li> </ul>	Inspection checklist
Installation of diversion banks is to consider the erodibility of the soils, slope gradients and lengths and are to be installed on a 1% grade to minimise erosion, where appropriate.	During construction	<ul style="list-style-type: none"> <li>– AIE Environmental Rep</li> <li>– Stage 2A Principal Contractor Environmental Rep and Stage 2B Principal Contractor Environmental Rep</li> <li>– Stage 2A Principal Contractor Construction Foreman and Stage 2B Principal Contractor Construction Foreman</li> </ul>	Inspection checklist
<b>De-watering</b>			
Wherever possible, water detained on site will be utilised for dust control and other non-potable uses.	During construction	<ul style="list-style-type: none"> <li>– AIE Environmental Rep</li> <li>– Stage 2A Principal Contractor Environmental Rep and Stage 2B Principal Contractor Environmental Rep</li> <li>– Stage 2A Principal Contractor Construction Foreman and Stage 2B Principal Contractor Construction Foreman</li> </ul>	Inspection checklist / Permit to Discharge
<b>Wet weather management</b>			
Prior to forecast rainfall events of 80% chance, 10mm in 24 hours or more, end of day controls will be	During construction	<ul style="list-style-type: none"> <li>– AIE Environmental Rep</li> <li>– Stage 2A Principal Contractor Environmental Rep and Stage 2B</li> </ul>	Inspection checklist

Measure/ Requirement	Timing	Responsibility	Evidence
considered to help reduce erosion and control sediment. These may include the following: <ul style="list-style-type: none"> <li>– Diversion banks.</li> <li>– Temporary ground cover (i.e., matting, soil binder).</li> </ul>		Principal Contractor Environmental Rep <ul style="list-style-type: none"> <li>– Stage 2A Principal Contractor Construction Foreman and Stage 2B Principal Contractor Construction Foreman</li> </ul>	
Prior to forecast heavy rainfall (80% chance, 15mm in 24 hours) the Stage 2A and Stage 2B Principal Contractor Environmental Representatives and Construction Foremen will inspect the site and note any areas requiring additional measures.	During construction	<ul style="list-style-type: none"> <li>– AIE Environmental Rep</li> <li>– Stage 2A Principal Contractor Environmental Rep and Stage 2B Principal Contractor Environmental Rep</li> <li>– Stage 2A Principal Contractor Construction Foreman and Stage 2B Principal Contractor Construction Foreman</li> </ul>	Inspection checklist
<b>Inspections and audits</b>			
<p>The Stage 2A and Stage 2B Principal Contractor Environmental Representatives will inspect all environmental controls measures across active works sites at least:</p> <ul style="list-style-type: none"> <li>– Weekly.</li> <li>– Prior to forecast rainfall of 80% chance, 10mm in 24 hours.</li> <li>– Daily during rain event*.</li> <li>– Post rainfall with runoff (&gt;10mm in 24 hours).</li> </ul> <p>Inspections will include checks of drainage, erosion and sediment controls to determine effectiveness and maintenance requirements. Inspections will consider issues such as:</p> <ul style="list-style-type: none"> <li>– Sediment transport and or deposition either on or off site.</li> <li>– Evidence of excessive erosion.</li> <li>– Maintenance, treatment and or de-watering requirements.</li> <li>– Stability of reinstatement, rehabilitation and revegetation works.</li> </ul>	During construction	<ul style="list-style-type: none"> <li>– AIE Environmental Rep</li> <li>– Stage 2A Principal Contractor Environmental Rep and Stage 2B Principal Contractor Environmental Rep</li> <li>– Stage 2A Principal Contractor Construction Foreman and Stage 2B Principal Contractor Construction Foreman</li> </ul>	Inspection checklist
Corrective maintenance to address any damage to erosion and sediment controls is to be scheduled and completed as soon as practicable.	During construction	<ul style="list-style-type: none"> <li>– AIE Environmental Rep</li> <li>– Stage 2A Principal Contractor Environmental Rep and Stage 2B Principal Contractor Environmental Rep</li> <li>– Stage 2A Principal Contractor Construction Foreman and Stage 2B Principal Contractor Construction Foreman</li> </ul>	Inspection checklist
Sediment controls will be cleaned out as required, no more than 5 days after rainfall. Sediment will be stockpiled or added to backfill.	During construction	<ul style="list-style-type: none"> <li>– AIE Environmental Rep</li> <li>– Stage 2A Principal Contractor Environmental Rep and Stage 2B Principal Contractor Environmental Rep</li> <li>– Stage 2A Principal Contractor Construction Foreman and Stage 2B Principal Contractor Construction Foreman</li> </ul>	Inspection checklist

Measure/ Requirement	Timing	Responsibility	Evidence
Within 5 days of the cessation of rainfall, ensure that sediment basins are in capacity to receive the amount of rain indicated on the progressive ESCP. If discharging is required, ensure that EPL No. 21529 discharge limit and relevant conditions are met.	During construction	<ul style="list-style-type: none"> <li>– AIE Environmental Rep</li> <li>– Stage 2A Principal Contractor Environmental Rep and Stage 2B Principal Contractor Environmental Rep</li> <li>– Stage 2A Principal Contractor Construction Foreman and Stage 2B Principal Contractor Construction Foreman</li> </ul>	<ul style="list-style-type: none"> <li>– Inspection checklist</li> <li>– Discharge Permit</li> </ul>
<b>Stabilisation and rehabilitation</b>			
Undertake progressive stabilisation and rehabilitation of ground surfaces as they are completed.	During construction	<ul style="list-style-type: none"> <li>– AIE Environmental Rep</li> <li>– Stage 2A Principal Contractor Environmental Rep and Stage 2B Principal Contractor Environmental Rep</li> <li>– Stage 2A Principal Contractor Construction Foreman and Stage 2B Principal Contractor Construction Foreman</li> </ul>	Inspection checklist
Sediment controls are to remain in place until their upslope catchment is stabilised.	During construction	<ul style="list-style-type: none"> <li>– AIE Environmental Rep</li> <li>– Stage 2A Principal Contractor Environmental Rep and Stage 2B Principal Contractor Environmental Rep</li> <li>– Stage 2A Principal Contractor Construction Foreman and Stage 2B Principal Contractor Construction Foreman</li> </ul>	Inspection checklist

\*Inspections will be dependent on safety issues present as conditions may be dangerous for site personnel during heavy rainfall. Inspections will not be undertaken during site shutdowns (Sundays and public holidays).

## 9. Monitoring and inspections

Monitoring and inspection activities will be undertaken with Section 8 of the Stage 2A and Stage 2B EMS.

Inspections will be undertaken of all active work fronts during construction activities and noted on the inspection checklist. Erosion and sediment control items will be part of the inspections.

Pre rainfall inspections will be undertaken prior to days when there is forecast to be an 80 per cent (or greater) chance of 20 millimetres of rain within the following 24-hour period, or at times when it is reasonably expected that runoff producing rainfall is to occur. Post rainfall inspections are to be undertaken in accordance with the EPL, and generally when the site received rain that caused runoff (approx. 20mm within 24 hours).

# References

ASRIS 2011, ASRIS - Australian Soil Resource Information System

BOM 2019, Climate statistics: Port Kembla Signal Station (068053)

DECC 2008, Managing Urban Stormwater: Soils and construction Volume 2A, Sydney: Department of Environment and Climate Change NSW.

Environment Protection Licence No. 21529, dated 3 December 2021.

GHD 2018, Contamination Assessment Report for Berth 101, s.l.: Australian Industrial Energy.

GHD 2018, Port Kembla Gas Terminal: Preliminary site investigation - pipeline alignment , s.l.: Australian Industrial Energy.

GHD 2019, Port Kembla Gas Terminal: Submissions Report, s.l.: AIE.

IECA 2008, Best Practice Erosion and Sediment Control, Picton, NSW: International Erosion Control Association (Australasia)

Infrastructure Approval SSI 9471 dated 13 October 2021.

Landcom 2004, Managing Urban Stormwater: Soils and Construction, Parramatta: Landcom.

SMEC March 2022, Port Kembla Gas Terminal Development – Emplacement Cell Report.

# Appendices



# **Appendix A**

**Standard design drawings**

## MATERIALS

**ROCK:** 150 TO 300mm EQUIVALENT DIAMETER, HARD, EROSION RESISTANT ROCK.

**SANDBAGS:** GEOTEXTILE BAGS (WOVEN SYNTHETIC, OR NON-WOVEN BIODEGRADABLE) FILLED WITH CLEAN COARSE SAND, CLEAN AGGREGATE, OR COMPOST.

## INSTALLATION (ROCK CHECK DAM)

1. REFER TO APPROVED PLANS FOR LOCATION AND INSTALLATION DETAILS. IF THERE ARE QUESTIONS OR PROBLEMS WITH THE LOCATION OR METHOD OF INSTALLATION CONTACT THE ENGINEER OR RESPONSIBLE ON-SITE OFFICER FOR ASSISTANCE.

2. PRIOR TO PLACEMENT OF THE SEDIMENT TRAP, ENSURE THE DRAINAGE CHANNEL IS DEEP ENOUGH TO PREVENT WATER BEING UNSAFELY DIVERTED OUT OF THE DRAIN ONCE THE CHECK DAMS ARE INSTALLED.

3. LOCATE EACH CHECK DAM SEDIMENT TRAP AS DIRECTED WITHIN THE APPROVED PLANS, OR OTHERWISE AT SUCH A SPACING TO ACHIEVE THE REQUIRED SEDIMENT TRAPPING OUTCOMES.

4. IF THE CHECK DAMS ARE ALSO BEING USED TO CONTROL EROSION WITHIN THE DRAINAGE CHANNEL, THEN LOCATE EACH SUCCESSIVE CHECK DAM SUCH THAT THE CREST OF THE IMMEDIATE DOWNSTREAM DAM IS LEVEL WITH THE CHANNEL INVERT AT THE IMMEDIATE UPSTREAM CHECK DAM.

5. CONSTRUCT EACH CHECK DAM TO THE DIMENSIONS AND PROFILE SHOWN WITHIN THE APPROVED PLAN.

6. WHERE SPECIFIED, THE CHECK DAMS MUST BE CONSTRUCTED ON A SHEET OF GEOTEXTILE FABRIC USED AS A DOWNSTREAM SPLASH PAD.

7. EACH CHECK DAM MUST BE EXTENDED UP THE CHANNEL BANK (WHERE PRACTICABLE) TO AN ELEVATION AT LEAST 150mm ABOVE THE CREST LEVEL OF THE DAM.

## INSTALLATION (COMPOST-FILLED SOCKS)

1. REFER TO APPROVED PLANS FOR LOCATION AND INSTALLATION DETAILS. IF THERE ARE QUESTIONS OR PROBLEMS WITH THE LOCATION OR METHOD OF INSTALLATION CONTACT THE ENGINEER OR RESPONSIBLE ON-SITE OFFICER FOR ASSISTANCE.

2. PRIOR TO PLACEMENT OF THE SEDIMENT TRAP, ENSURE THE DRAINAGE CHANNEL IS DEEP ENOUGH TO PREVENT WATER BEING UNSAFELY DIVERTED OUT OF THE DRAIN ONCE THE CHECK DAMS ARE INSTALLED.

3. LOCATE EACH SOCK AS DIRECTED WITHIN THE APPROVED PLANS, OR OTHERWISE AT SUCH A SPACING TO ACHIEVE THE REQUIRED SEDIMENT TRAPPING OUTCOMES.

4. PLACE EACH SOCK TO THE LINES AND PROFILE SHOWN IN THE APPROVED PLAN OR AS DIRECTED BY THE SITE SUPERVISOR.

5. ENSURE EACH SOCK EXTENDS UP THE CHANNEL BANKS (WHERE PRACTICAL) TO A LEVEL AT LEAST 100mm ABOVE THE CREST LEVEL OF THE CHECK DAM.

## MAINTENANCE

1. INSPECT EACH CHECK DAM AND THE DRAINAGE CHANNEL AT LEAST WEEKLY AND AFTER RUNOFF-PRODUCING RAINFALL.

2. CORRECT ALL DAMAGE IMMEDIATELY. IF SIGNIFICANT EROSION OCCURS BETWEEN ANY OF THE CHECK DAMS, THEN CHECK THE SPACING OF THE DAMS AND WHERE NECESSARY INSTALL INTERMEDIATE CHECK DAMS OR A SUITABLE CHANNEL LINER.

3. CHECK FOR DISPLACEMENT OF THE CHECK DAMS.

4. CHECK FOR SOIL SCOUR AROUND THE ENDS OF EACH CHECK DAM. IF SUCH EROSION IS OCCURRING, CONSIDER EXTENDING THE WIDTH OF THE CHECK DAM TO AVOID SUCH PROBLEMS.

5. IF SEVERE SOIL EROSION OCCURS EITHER UNDER OR AROUND THE CHECK DAMS, THEN SEEK EXPERT ADVICE ON AN ALTERNATIVE TREATMENT MEASURE.

6. DE-SILT SEDIMENT TRAP IF THE SEDIMENT LEVEL EXCEEDS 1/3 THE CREST HEIGHT.

7. DISPOSE OF COLLECTED SEDIMENT IN A SUITABLE MANNER THAT WILL NOT CAUSE AN EROSION OR POLLUTION HAZARD.

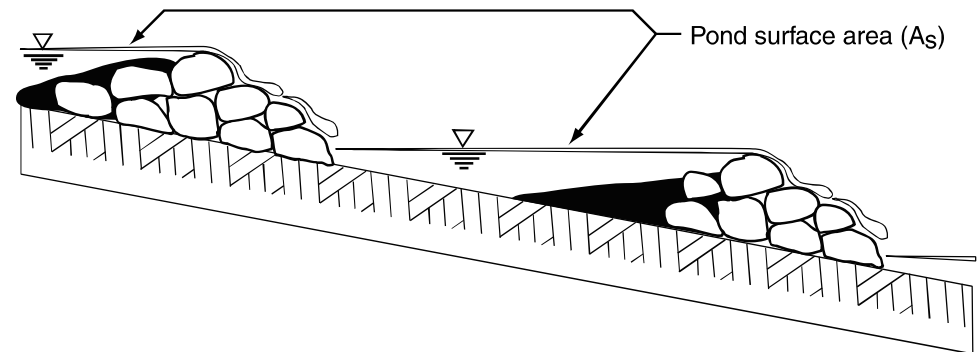
## REMOVAL

1. WHEN CONSTRUCTION WORK WITHIN THE DRAINAGE AREA ABOVE THE CHECK DAMS HAS BEEN COMPLETED AND DISTURBED AREAS SUFFICIENTLY STABILISED TO RESTRAIN EROSION, THE DAMS MUST BE REMOVED, UNLESS THE SEDIMENT TRAPS ARE TO REMAIN AS A PERMANENT FEATURE.

2. REMOVE COLLECTED SEDIMENT AND DISPOSE OF IN A SUITABLE MANNER THAT WILL NOT CAUSE AN EROSION OR POLLUTION HAZARD.

3. REMOVE AND APPROPRIATELY DISPOSE OF ALL MATERIALS INCLUDING ANY GEOTEXTILE FABRIC.

4. STABILISE THE DISTURBED CHANNEL WITH A LINING OF FABRIC AND ROCK, OR ESTABLISH VEGETATION AS APPROPRIATE.



**Figure 1 - Placement of check dam sediment traps**

Drawn:	Date:	Check Dam Sediment Trap	CDT-01
GMW	Apr-10		

## MATERIALS

UNLESS OTHERWISE SPECIFIED, THE FOLLOWING MATERIAL SPECIFICATIONS SHOULD APPLY.

### GEOTEXTILE BLANKETS:

- (i) WOVEN POLYPROPYLENE FABRIC.
- (ii) MINIMUM THICKNESS OF 1.5mm.
- (iii) MINIMUM WIDTH OF 3.6m.

### STAPLES:

- (i) MINIMUM 11 GAUGE STEEL WIRE.
- (ii) U-SHAPED WITH 200mm LEG LENGTH AND 50mm CROWN.

### EXCELSIOR BLANKETS:

- (i) CURLED WOOD FIBRE BLANKET WITH 80% OF FIBRES LONGER THAN 150mm.
- (ii) MINIMUM ROLL WIDTH OF 1200mm.
- (iii) AVERAGE WEIGHT OF 0.43kg/m<sup>2</sup> +/-10%.

### STRAW BLANKETS:

- (i) MINIMUM ROLL WIDTH OF 2m.
- (ii) MINIMUM WEIGHT OF 0.27kg/m<sup>2</sup>.

### COCONUT FIBRE BLANKETS:

- (i) MINIMUM ROLL WIDTH OF 2m.
- (ii) MINIMUM WEIGHT OF 0.27kg/m<sup>2</sup>.

## INSTALLATION

THE METHOD OF INSTALLATION VARIES WITH THE TYPE OF MATERIAL USED AND THE TASK BEING PERFORMED BY THE BLANKET. INSTALLATION PROCEDURES SHOULD BE SUPPLIED BY THE MANUFACTURER OR DISTRIBUTOR OF THE PRODUCT. A TYPICAL INSTALLATION PROCEDURE FOR ROLLED EROSION CONTROL PRODUCTS IS DESCRIBED BELOW.

## APPLICATION OF ROLLED BLANKETS ON SLOPES NOT SUBJECTED TO CONCENTRATED FLOW:

1. REFER TO APPROVED PLANS FOR LOCATION, EXTENT, AND INSTALLATION DETAILS. IF THERE ARE QUESTIONS OR PROBLEMS WITH THE LOCATION, EXTENT, OR METHOD OF INSTALLATION CONTACT THE ENGINEER OR RESPONSIBLE ON-SITE OFFICER FOR ASSISTANCE.
2. CLEAR AWAY TRASH AND LARGE STONES, AND GRADE SMOOTHLY TO ELIMINATE FOOTPRINTS, TRACKS AND RUTS.
3. PREPARE A SMOOTH SEEDBED OF APPROXIMATELY 75mm OF TOPSOIL.
4. APPLY SEED, SOIL AMELIORANTS AND WATER AS SPECIFIED, THEN RAKE TO REMOVE ANY REMAINING SURFACE IRREGULARITIES.
5. COMMENCE PLACEMENT OF THE BLANKETS AT THE TOP OF THE SLOPE. BURY THE UPPER EDGE OF THE BLANKET WITHIN A 300mm DEEP TRENCH AND STAPLE AT 200 TO 250mm CENTRES.
6. THE BLANKETS CAN BE PLACED LENGTHWISE EITHER ALONG THE SLOPE (PARALLEL TO THE CONTOURS) OR DOWN THE SLOPE (TRANSVERSE TO THE CONTOURS), BUT NOT DIAGONALLY ACROSS THE SLOPE.
7. OVERLAP THE SIDES OF EACH BLANKET BY AT LEAST 100mm.
8. BURY THE EDGE OF THE BLANKET LOCATED ALONG THE OUTER MOST EDGE OF THE TREATED AREA WITHIN A 300mm DEEP TRENCH AND STAPLE THE BLANKET WITHIN THE TRENCH AT 200 TO 250mm CENTRES.

9. WHERE MORE THAN ONE BLANKET IS USED DOWN THE SLOPE, OVERLAP EACH BLANKET BY AT LEAST 300mm WITH THE UPPER BLANKET PLACED OVER THE LOWER BLANKET (SHINGLE STYLE).

10. WHEN SPREADING THE BLANKETS, AVOID STRETCHING THE FABRIC. THE BLANKETS SHOULD REMAIN IN GOOD CONTACT WITH THE SOIL.

11. STAPLE THE EXPOSED FABRIC SURFACE AT 1m CENTRES.

12. BLANKETS, ONCE FIXED, MAY BE ROLLED WITH A ROLLER WEIGHING 60 TO 90kg/m LENGTH, THEN WATERED.

13. THE INSTALLATION PROCEDURE MUST ENSURE THAT THE BLANKET ACHIEVES AND RETAINS INTIMATE CONTACT WITH THE SOIL.

14. DAMAGED FABRIC SHALL BE REPAIRED OR REPLACED.

15. WHERE DIRECTED, AN ADDITIONAL MESH (JUTE OR COIR) ANCHOR MAY NEED TO BE PLACED OVER THE BLANKETS TO MINIMISE DISPLACEMENT BY STRONG WINDS.

## ADDITIONAL REQUIREMENTS ASSOCIATED WITH USE NEAR AIRPORT PAVEMENTS:

1. ONLY BLANKETS THAT ARE DOUBLE NETTED SHALL BE ALLOWED WITHIN 3m OF ANY AIRPORT PAVEMENT USED BY AIRCRAFT WITH THE EXCEPTION OF AIRPORTS CLASSIFIED AS AIR CARRIER OR CORPORATE/TRANSPORT. IF THE AIRPORT IS CLASSIFIED AS AN AIR

CARRIER OR CORPORATE/TRANSPORT, THERE WILL BE NO BLANKETS ALLOWED WITHIN 9m OF PAVEMENT USED BY AIRCRAFT.

2. ONLY BIODEGRADABLE ANCHORING DEVICES SHALL BE ALLOWED IN THE INSTALLATION OF ANY BLANKET FOR AIRPORT APPLICATIONS. NO METAL STAPLES WILL BE ALLOWED.

## MAINTENANCE

1. DURING THE ACTIVE CONSTRUCTION PERIOD, INSPECT THE TREATED AREA FORTNIGHTLY AND AFTER RUNOFF-PRODUCING STORM EVENTS AND MAKE REPAIRS AS NEEDED.

2. THE TREATED AREA SHOULD BE INSPECTED AT LEAST FORTNIGHTLY FOR THE FIRST 3 MONTHS.

3. INSPECT THE TREATED AREA TO SEE IF:

- (i) CONSTRUCTION ACTIVITY OR FALLING DEBRIS HAVE DAMAGED THE BLANKETS;
- (ii) RUNOFF IS UNDERMINING THE FABRIC;
- (iii) THE BLANKETS ARE IN GOOD CONTACT WITH THE SOIL; AND
- (iv) THE BLANKETS MAINTAIN ADEQUATE OVERLAP.

4. IF DAMAGED, REPAIR OR REPLACE THE DAMAGED SECTION. IF WATER IS UNDERMINING THE FABRIC, REPAIR ANY HOLES OR JOINTS OR RE-BURY THE UPPER ENDS OF THE DAMAGED SECTIONS.

Drawn:	Date:		
GMW	May-10	Erosion Control Blankets	ECB-01

## MATERIALS

**FIBRE ROLLS:** TYPICALLY 200 TO 250mm JUTE, COIR OR STRAW ROLL TIED WITH SYNTHETIC OR BIODEGRADABLE MESH.

**STAKES:** MINIMUM 25 x 25mm TIMBER STAKES.

## INSTALLATION

1. REFER TO APPROVED PLANS FOR LOCATION AND INSTALLATION DETAILS. IF THERE ARE QUESTIONS OR PROBLEMS WITH THE LOCATION, DIMENSIONS OR METHOD OF INSTALLATION CONTACT THE ENGINEER OR RESPONSIBLE ON-SITE OFFICER FOR ASSISTANCE.

2. WHEN PLACED ACROSS NON-VEGETATED OR NEWLY SEEDED SLOPES, THE ROLLS MUST BE PLACED ALONG THE CONTOUR.

3. IF PLACED ON OPEN OR LOOSE SOIL, ENSURE THE FIBRE ROLLS ARE TRENCHED 75 TO 125mm IN SANDY SOILS AND 50 TO 75mm IN CLAYEY SOILS.

4. ENSURE THE OUTER MOST ENDS OF THE FIBRE ROLL ARE TURNED UP THE SLOPE TO ALLOW WATER TO ADEQUATELY POND UP-SLOPE OF THE ROLL, AND TO MINIMISE FLOW BYPASSING.

5. WHEN PLACED ACROSS THE INVERT OF MINOR DRAINS, ENSURE THE SOCKS ARE PLACED SUCH THAT:

- (i) THE CREST OF THE DOWNSTREAM ROLL IS LEVEL WITH THE CHANNEL INVERT AT THE IMMEDIATE UPSTREAM SOCK (IF ANY);
- (ii) EACH ROLL EXTENDS UP THE CHANNEL BANKS SUCH THAT THE CREST

OF THE FIBRE ROLL AT ITS LOWEST POINT IS LOWER THAN THE GROUND LEVEL AT EITHER END OF THE ROLL.

6. ENSURE THE ANCHORING STAKES ARE DRIVEN INTO THE END OF EACH ROLL AND ALONG THE LENGTH OF EACH ROLL AT A SPACING NOT EXCEEDING 1.2m OR SIX TIMES THE ROLL DIAMETER, WHICHEVER IS THE LESSER. A MAXIMUM STAKE SPACING OF 0.3m APPLIES WHEN USED TO FORM CHECK DAMS.

7. ADJOINING ROLL MUST BE OVERLAP AT LEAST 450mm, NOT ABUTTED.

## MAINTENANCE

1. INSPECT ALL FIBRE ROLLS PRIOR TO FORECAST RAIN, DAILY DURING EXTENDED PERIODS OF RAINFALL, AFTER SIGNIFICANT RUNOFF PRODUCING STORMS OR OTHERWISE AT WEEKLY INTERVALS.

2. REPAIR OR REPLACE DAMAGED FIBRE ROLLS.

3. REMOVE COLLECTED SEDIMENT AND DISPOSE OF IN A SUITABLE MANNER THAT WILL NOT CAUSE AN EROSION OR POLLUTION HAZARD.

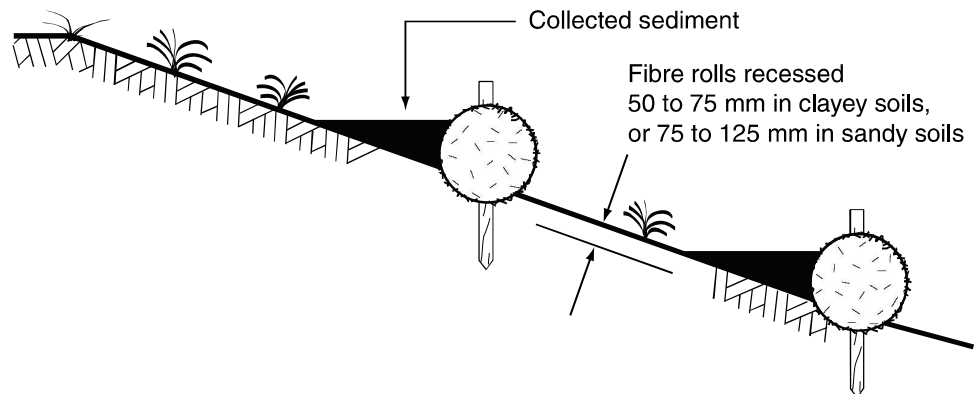
## REMOVAL

1. ALL EXCESSIVE SEDIMENT TRAPPED BY THE ROLLS MUST BE REMOVED FROM THE DRAIN OR SLOPE IF SUCH SEDIMENT IS LIKELY TO BE WASHED AWAY BY EXPECTED FLOWS.

2. DISPOSE OF COLLECTED SEDIMENT IN A SUITABLE MANNER THAT WILL NOT CAUSE AN EROSION OR POLLUTION HAZARD.

3. THE BIODEGRADABLE CONTENT OF THE STRAW ROLLS MAY NOT NECESSARILY NEED TO BE REMOVED FROM THE SITE.

4. ALL SYNTHETIC (PLASTIC) MESH OR OTHER NON READILY BIODEGRADABLE MATERIAL MUST BE REMOVED FROM THE SITE ONCE THE SLOPE OR DRAIN IS STABILISED, OR THE ROLLS HAVE DETERIORATED TO A POINT WHERE THEY ARE NO LONGER PROVIDING THEIR INTENDED DRAINAGE OR SEDIMENT CONTROL FUNCTION.



**Figure 1 - Typical installation of fibre rolls**

Drawn:	Date:		
GMW	Apr-10	Fibre Rolls	FR-01

## MATERIALS

**FILTER TUBE:** MANUFACTURED FROM A NON-WOVEN GEOTEXTILE REINFORCED WITH A UV-STABILISED, WOVEN FABRIC OR POLY-PROPYLENE MESH. THE GEOTEXTILE FABRIC SHOULD BE EITHER POLYESTER OR POLYPROPYLENE. PROPERTIES (AS3706) MINIMUM WIDE STRIP TENSILE STRENGTH OF 20kN/m IN BOTH DIRECTIONS; PORE SIZE EOS LESS THAN 160MICRONS, O95 LESS THAN 90MICRONS; MINIMUM MASS OF 300GSM (MINIMUM 'BIDIM' A44 OR EQUIVALENT).

**RIBBED PIPE (USED WITH EARTH BANKS):** RIBBED, PVC OR SIMILAR PIPE.

**EARTH EMBANKMENT:** NON-DISPERSIVE (EMERSON'S AGGREGATE CLASS 6, 7 OR 8) CLEAN EARTH FILL, FREE OF ORGANIC DEBRIS AND WITH SUFFICIENT CLAY CONTENT TO PREVENT THE THROUGH-FLOW OF WATER.

## INSTALLATION

1. REFER TO APPROVED PLANS FOR LOCATION, EXTENT, AND DETAILS. IF THERE ARE QUESTIONS OR PROBLEMS WITH THE LOCATION, EXTENT, OR METHOD OF INSTALLATION CONTACT THE ENGINEER OR RESPONSIBLE ON-SITE OFFICER FOR ASSISTANCE.

2. CONSTRUCT A SUITABLE WATER-RETAINING BARRIER/EMBANKMENT OUT OF THE MATERIAL SPECIFIED WITHIN THE APPROVED PLANS.

3. WHILE CONSTRUCTING THE DAM OR EMBANKMENT, INSTALL AND ANCHOR THE SPECIFIED NUMBER OF RIBBED PIPE SECTIONS THROUGH THE DAM/ EMBANKMENT.

4. ENSURE THE INLETS TO EACH FILTER TUBE ARE APPROPRIATELY ELEVATED ABOVE THE ADJACENT GROUND LEVEL TO MINIMISE THE RISK OF SEDIMENT BLOCKAGE OF THE PIPE ENTRANCE.

5. FOR EARTH EMBANKMENT, FIRMLY HAND-TAMP THE EARTH UNDER AND AROUND THE RIPPED PIPE/S IN LIFTS NOT EXCEEDING 100mm. ENSURE THAT ALL FILL MATERIAL IS WELL-COMPACTED.

6. FOR EARTH EMBANKMENTS, ENSURE THAT THE EMBANKMENT HAS MINIMUM DIMENSIONS OF 500mm HEIGHT, WITH 200mm CLEARANCE OVER THE PIPE OBVERT, AND MAXIMUM 2:1(H:V) SIDE SLOPES.

7. SUITABLY CONNECT THE FILTER TUBES TO THE DOWNS-SLOPE END OF THE PROTRUDING CONNECTOR PIPES. ENSURE ALL CONNECTIONS ARE WATERTIGHT.

## MAINTENANCE

1. INSPECT THE BARRIER/EMBANKMENT AND FILTER TUBES REGULARLY AND AT LEAST DAILY DURING DE-WATERING OPERATIONS. MAKE REPAIRS AS NEEDED TO THE FABRIC.

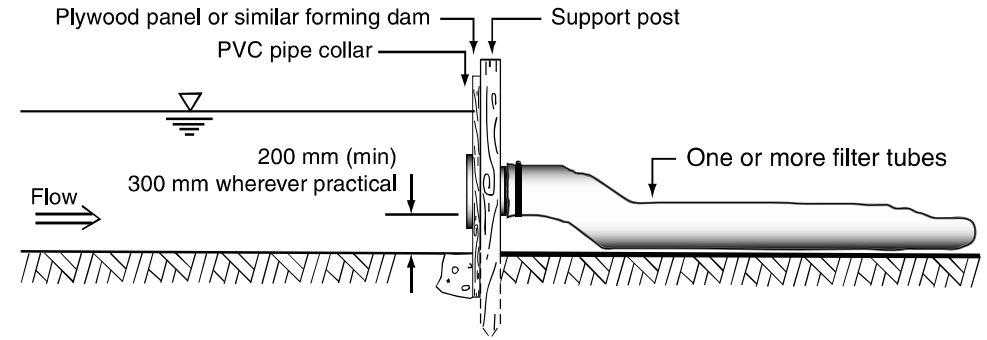
2. INSPECT THE FILTER TUBES FOR OBVIOUS LEAKS RESULTING FROM HOLES, TEARS OR JOINT FAILURE IN THE FABRIC.

3. REPAIR OR REPLACE ANY FILTER TUBE AS NECESSARY TO MAINTAIN THE DESIRED OPERATIONAL PERFORMANCE. IN SOME CIRCUMSTANCES FLOW RATE THROUGH THE FILTER TUBES CAN BE TEMPORARILY IMPROVED BY BRUSHING THE BAG WITH A STIFF-BRISTLED BROOM.

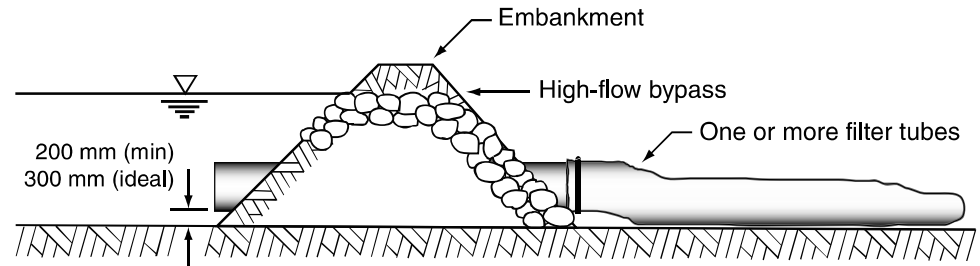
4. REPLACE ANY FILTER TUBE IF SEDIMENT BLOCKAGE OF THE FABRIC DECREASES THE FLOW RATE TO AN UNACCEPTABLE LEVEL, OR THE FILTER TUBE CONTAINS EXCESSIVE SEDIMENT.

## REMOVAL

1. REMOVE OF ALL MATERIALS AND DISPOSE OF THEM IN A SUITABLE MANNER THAT WILL NOT CAUSE AN ONGOING EROSION OR POLLUTION HAZARD.



(a) Filter tubes incorporated a solid, impervious dam



(b) Filter tubes incorporated into an earth embankment

Drawn:	Date:		
GMW	Apr-10	Filter Tube Dam	FTD-01

**CAUTION; SPECIFICATIONS FOR SITE REVEGETATION VARY CONSIDERABLY FROM SITE TO SITE. SITE SUPERVISORS SHOULD OBTAIN SITE SPECIFIC PLANTING SPECIFICATIONS.**

**INSTALLATION**

1. REFER TO APPROVED PLANS FOR LOCATION, EXTENT, AND APPLICATION DETAILS. IF THERE ARE QUESTIONS OR PROBLEMS WITH THE LOCATION, EXTENT, OR METHOD OF APPLICATION CONTACT THE ENGINEER, LANDSCAPE ARCHITECT OR RESPONSIBLE ON-SITE OFFICER FOR ASSISTANCE.
2. ENSURE ALL NECESSARY SOIL TESTING (e.g. SOIL pH, NUTRIENT LEVELS) AND ANALYSIS HAS BEEN COMPLETED, AND REQUIRED SOIL ADJUSTMENTS PERFORMED PRIOR TO PLANTING.
3. APPLY SOIL CONDITIONERS AND FERTILISER AS SPECIFIED ON THE APPROVED PLANS. RIP THE SOIL 100 TO 150mm TO MIX THE COMPONENTS INTO THE SOIL AND TO LOOSEN AND ROUGHEN THE SOIL SURFACE BEFORE SEEDING.
4. WHERE POSSIBLE, THERE SHOULD BE SUFFICIENT SOIL DEPTH TO PROVIDE AN ADEQUATE ROOT ZONE. THE DEPTH TO ROCK OR IMPERMEABLE LAYERS SUCH AS HARDPANS SHOULD BE 300mm OR MORE, EXCEPT ON SLOPES STEEPER THAN 2:1(H:V) WHERE SUCH SOIL DEPTH MAY NOT BE FEASIBLE.
5. ENSURE THE SOIL pH IS WITHIN THE SPECIFIED RANGE.
6. APPLY SEED UNIFORMLY BY HAND OR WITH A CYCLONE SEEDER, DROP-TYPE SPREADER, DRILL, HYDROSEEDER, HYDROMULCHER, OR OTHER SUITABLE EQUIPMENT AS SPECIFIED.
7. WHEN USING BROADCAST-SEEDING METHODS, SUBDIVIDE THE AREA INTO WORKABLE SECTIONS AND APPLY ONE-HALF THE SPECIFIED QUANTITY OF SEED WHILE MOVING BACK AND FORTH ACROSS THE AREA, MAKING A UNIFORM PATTERN. THEN APPLY THE SECOND HALF IN THE SAME WAY, BUT MOVING AT RIGHT ANGLES TO THE FIRST PASS. COVER BROADCAST SEED BY RAKING

OR CHAIN DRAGGING; THEN FIRM THE SURFACE WITH A ROLLER TO PROVIDE GOOD SEED CONTACT.

8. APPLY SEED AT THE RECOMMENDED RATE, AND DISC OR OTHERWISE MECHANICALLY TREAT THE SURFACE TO BRING THE SEED INTO CONTACT WITH THE SOIL.
9. THE SEEDED AREA SHOULD BE MULCHED AS SPECIFIED IN THE APPROVED PLAN.

**MAINTENANCE**

1. DURING THE CONSTRUCTION PHASE, INSPECT THE TREATED AREA FORTNIGHTLY AND AFTER RUNOFF-PRODUCING RAINFALL. MAKE REPAIRS AS NEEDED.
2. WATERING THE VEGETATION PERIODICALLY IS ESSENTIAL, ESPECIALLY IN THE FIRST 7 DAYS AFTER ESTABLISHMENT. USE LOW-PRESSURE SPRAYS BECAUSE HIGH-PRESSURE JETS CAN WASH AWAY THE SEED AND MULCH COVER.
3. WATERING SHOULD START IMMEDIATELY AFTER PLANTING. WATERING SHOULD COMPLY WITH SPECIFICATIONS PROVIDED WITH THE APPROVED PLANS. GENERALLY WATERING SHOULD VARY ACCORDING TO WEATHER AND SOIL CONDITIONS. A TYPICAL WATERING SCHEDULE MAY CONSIST OF THE FOLLOWING:
  - (i) 25mm EVERY SECOND DAY FOR THE FIRST THREE WATERINGS;
  - (ii) 25mm TWICE A WEEK FOR THE NEXT THREE WEEKS; AND
  - (iii) 25mm ONCE WEEKLY FOR A FURTHER TWO WEEKS.
4. MONITOR SITE REVEGETATION, PARTICULARLY AFTER RAINFALL, AND APPROPRIATE MAINTENANCE AND/OR AMENDMENT TO ENSURE THAT THE REVEGETATION IS CONTROLLING EROSION AND STABILISING SOIL SLOPES AS REQUIRED.
5. WHERE PRACTICABLE, FILL IN, OR LEVEL OUT, ANY RILL EROSION BETWEEN PLANTS. IF EXCESSIVE EROSION OCCURS, THEN CONSIDER INCREASING THE PLANTING DENSITY, APPLYING APPROPRIATE EROSION CONTROL MEASURES, OR INTRODUCING ALTERNATIVE, NON-CLUMPING PLANT SPECIES.

6. AREAS MUST BE RE-SEEDED AND MULCHED IF THE VEGETATION FAILS TO ESTABLISH OR IS DAMAGED BY RUNOFF OR CONSTRUCTION ACTIVITIES.

7. IF THE TEMPORARY VEGETATION COVER OR EROSION CONTROL MEASURE (e.g. MULCH COVER) SHOULD FAIL FOR ANY REASON BEFORE ESTABLISHMENT OF THE PERMANENT VEGETATION COVER, THEN IT MUST BE REPLACED WITH AN APPROPRIATE TYPE OF COVER SUFFICIENT TO CONTROL SOIL EROSION.
8. IF THE PERMANENT VEGETATION SHOULD FAIL TO ESTABLISH OR TO ADEQUATELY RESTRAIN EROSION FOR ANY REASON DURING THE CONSTRUCTION OR MAINTENANCE PERIOD, THE AREA SHOULD BE REVEGETATED OR PROTECTED WITH OTHER EROSION CONTROL MEASURES AS APPROPRIATE.
9. IN AREAS WHERE THE OBTAINED VEGETATION COVER IS CONSIDERED INADEQUATE FOR EROSION CONTROL, THE AFFECTED AREA SHOULD BE OVER-SEEDED AND FERTILISED USING HALF THE ORIGINALLY SPECIFIED RATES, OR AS DIRECTED.
10. MAINTAIN GRASS BLADE LENGTH AT A MINIMUM 50mm HEIGHT WITHIN MEDIUM TO HIGH VELOCITY DRAINAGE AREAS, AND 20 TO 50mm WITHIN LOW VELOCITY FLOW PATHS.
11. WHERE NECESSARY, OR AS DIRECTED BY THE SITE SUPERVISOR, SLASH THE TEMPORARY CROP/GRASS COVER TO ALLOW THE SUCCESSFUL GROWTH OF THE UNDERLYING PERMANENT VEGETATION COVER.
12. CONTROL WEED GROWTH WITHIN 1m OF IMMATURE TREES FOR 6 TO 12 MONTHS FOR FAST GROWING SPECIES, AND 18 TO 20 MONTHS FOR SLOWER GROWING SPECIES, OR UNTIL THE END OF THE SPECIFIED MAINTENANCE PERIOD.
13. WHERE MULCH IS USED TO CONTROL WEED GROWTH, INSPECT AND WHERE NECESSARY, RENEW AT MAINTENANCE PERIODS NOT EXCEEDING 4 TO 6 MONTHS.

14. APPLY ADDITIONAL SEED, MULCH AND/OR SOIL CONDITIONING AS REQUIRED. MULCHES USUALLY NEED TO BE MAINTAINED OR RENEWED (AS NECESSARY) 2 TO 3 TIMES A YEAR.

15. INSPECT AND WHERE NECESSARY REPAIR PROTECTIVE FENCING AT MAINTENANCE PERIODS NOT EXCEEDING 1 MONTH.
16. RE-FIRM PLANTS LOOSENED BY WIND-ROCK, LIVESTOCK OR WILDLIFE.
17. REPLACE DEAD OR SEVERELY RETARDED PLANTS.
18. PRUNE ANY PLANTS OF DEAD OR DISEASED PARTS. CUT OFF ALL DAMAGED TREE LIMBS ABOVE THE TREE COLLAR AT THE TRUNK OR MAIN BRANCH. USE SEVERAL CUTS INCLUDING UNDERCUTTING TO AVOID PEELING BARK FROM THE HEALTHY AREAS OF THE TREE.
19. DISPOSE OF CLEARED VEGETATION IN AN APPROPRIATE MANNER SUCH AS CHIPPING OR MULCHING, ON-SITE BURIAL, OR OFF-SITE DISPOSAL. CLEARED VEGETATION SHOULD NOT BE DUMPED NEAR A WATERCOURSE OR ON A FLOODPLAIN WHERE IS COULD BE REMOVED BY FLOODWATERS. VEGETATION SHOULD NOT BE BURNT ON-SITE WITHOUT SPECIFIC APPROVAL FROM THE LOCAL AUTHORITY.
20. REPAIR DAMAGED TREE ROOTS BY CUTTING OFF THE DAMAGED AREAS AND SEALING THEM WITH AN APPROVED PRODUCT. SPREAD MOIST TOPSOIL OVER EXPOSED ROOTS.

Drawn:	Date:		
GMW	Dec-09	Revegetation - General	R-01

## MATERIALS

**ROCK:** 150 TO 300mm NOMINAL DIAMETER, HARD, EROSION RESISTANT ROCK. SMALLER ROCK MAY BE USED IF SUITABLE LARGE ROCK IS NOT AVAILABLE.

**SANDBAGS:** GEOTEXTILE BAGS (WOVEN SYNTHETIC, OR NON-WOVEN BIODEGRADABLE) FILLED WITH CLEAN COARSE SAND, CLEAN AGGREGATE, STRAW OR COMPOST.

## INSTALLATION

1. REFER TO APPROVED PLANS FOR LOCATION AND INSTALLATION DETAILS. IF THERE ARE QUESTIONS OR PROBLEMS WITH THE LOCATION OR METHOD OF INSTALLATION, CONTACT THE ENGINEER OR RESPONSIBLE ON-SITE OFFICER FOR ASSISTANCE.

2. PRIOR TO PLACEMENT OF THE CHECK DAMS, ENSURE THE TYPE AND SIZE OF EACH CHECK DAMS WILL NOT CAUSE A SAFETY HAZARD OR CAUSE WATER TO SPILL OUT OF THE DRAIN.

3. LOCATE THE FIRST CHECK DAM AT THE DOWNSTREAM END OF THE SECTION OF CHANNEL BEING PROTECTED. LOCATE EACH SUCCESSIVE CHECK DAM SUCH THAT THE CREST OF THE IMMEDIATE DOWNSTREAM DAM IS LEVEL WITH THE TOE OF THE CHECK DAM BEING INSTALLED.

4. ENSURE THE CHANNEL SLOPE IS NO STEEPER THAN 10:1 (H:V). OTHERWISE CONSIDER THE USE OF A SUITABLE CHANNEL LINER INSTEAD OF THE CHECK DAMS.

5. CONSTRUCT THE CHECK DAM TO THE DIMENSIONS AND PROFILE SHOWN WITHIN THE APPROVED PLAN.

6. WHERE SPECIFIED, THE CHECK DAMS SHALL BE CONSTRUCTED ON A SHEET OF GEOTEXTILE FABRIC USED AS A DOWNSTREAM SPLASH PAD.

7. EACH CHECK DAM SHALL BE EXTENDED UP THE CHANNEL BANK (WHERE PRACTICABLE) TO AN ELEVATION AT LEAST 150mm ABOVE THE CREST LEVEL OF THE DAM.

## MAINTENANCE

1. INSPECT EACH CHECK DAM AND THE DRAINAGE CHANNEL AT LEAST WEEKLY AND AFTER RUNOFF-PRODUCING RAINFALL.

2. CORRECT ALL DAMAGE IMMEDIATELY. IF SIGNIFICANT EROSION OCCURS BETWEEN ANY OF THE CHECK DAMS, THEN CHECK THE SPACING OF DAMS AND WHERE NECESSARY INSTALL INTERMEDIATE CHECK DAMS OR A SUITABLE CHANNEL LINER.

3. CHECK FOR DISPLACEMENT OF THE CHECK DAMS

4. CHECK FOR SOIL SCOUR AROUND THE ENDS OF EACH CHECK DAM. IF SUCH EROSION IS OCCURRING, CONSIDER EXTENDING THE WIDTH OF THE CHECK DAM TO AVOID SUCH PROBLEMS.

5. IF SEVERE SOIL EROSION OCCURS EITHER UNDER OR AROUND THE CHECK DAMS, THEN SEEK EXPERT ADVICE ON AN ALTERNATIVE TREATMENT MEASURE.

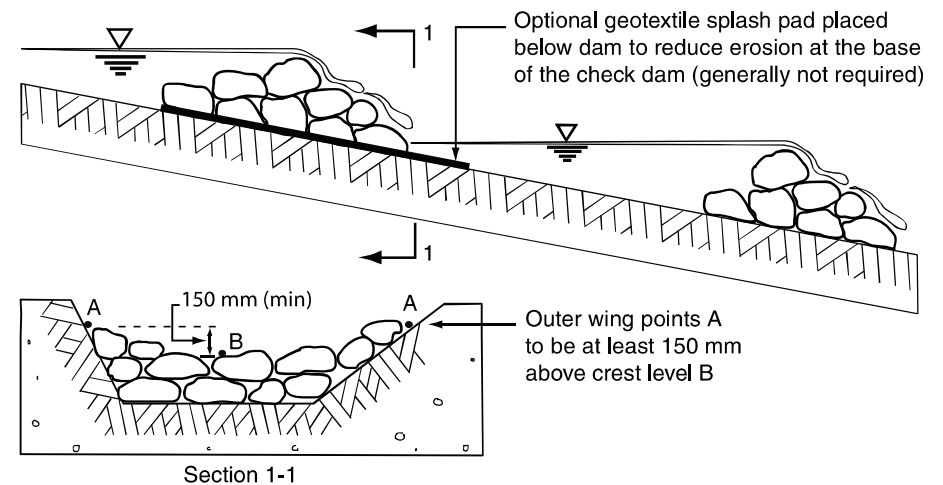
6. REMOVE ANY SEDIMENT ACCUMULATED BY THE CHECK DAMS, UNLESS IT IS INTENDED THAT THIS SEDIMENT WILL REMAIN WITHIN THE CHANNEL.

7. DISPOSE OF COLLECTED SEDIMENT IN A SUITABLE MANNER THAT WILL NOT CAUSE AN EROSION OR POLLUTION HAZARD.

## REMOVAL

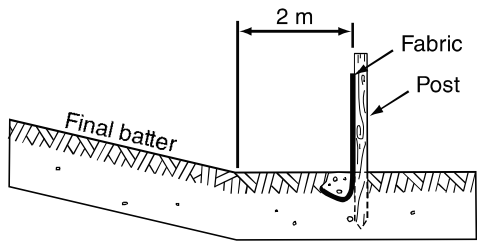
1. WHEN CONSTRUCTION WORK WITHIN THE DRAINAGE AREA ABOVE THE CHECK DAMS HAS BEEN COMPLETED, AND THE DISTURBED AREAS AND THE DRAINAGE CHANNEL ARE SUFFICIENTLY STABILISED TO RESTRAIN EROSION, ALL TEMPORARY CHECK DAMS MUST BE REMOVED.

2. REMOVE THE CHECK DAMS AND ASSOCIATED SEDIMENT AND DISPOSE OF IN A SUITABLE MANNER THAT WILL NOT CAUSE AN EROSION OR POLLUTION HAZARD.

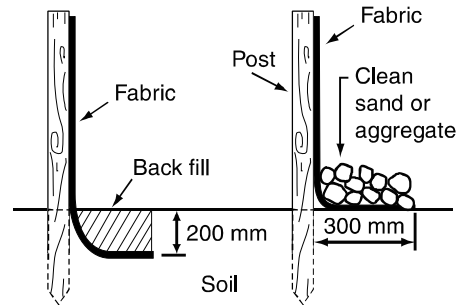


**Figure 1 - Layout and profile of check dams (rock check dams shown)**

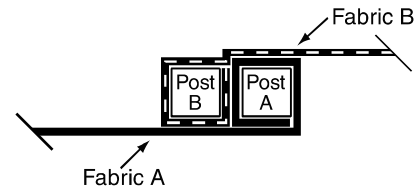
Drawn:	Date:		
GMW	Dec-09	Check Dams	RCD-01



(a) Location of fence relative to base of slope

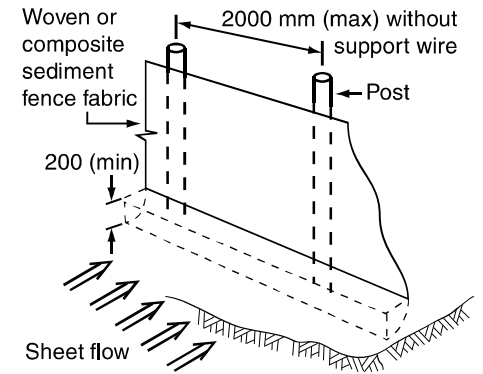


(b) Anchoring base of fabric

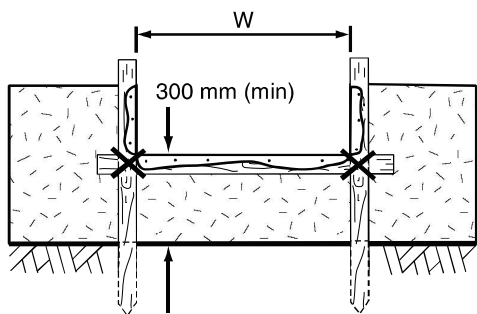


Fabric to fold around each stake one full turn. Stake B to be drive tightly against Stake A. The tops of both stakes to be secured with wire.

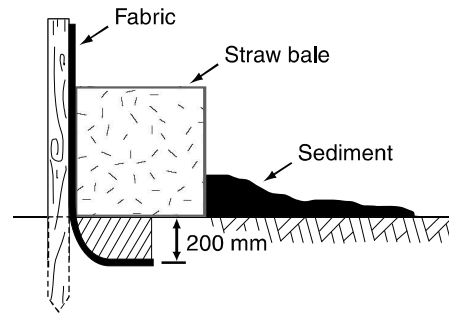
(c) Joining fabric - Method 1



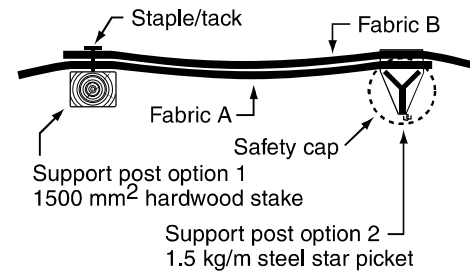
(d) Installation without backing support



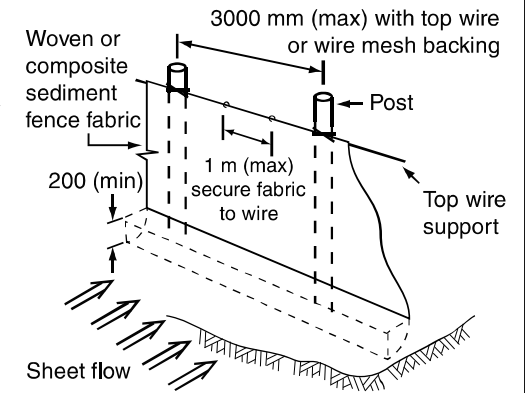
(e) Spill-through weir



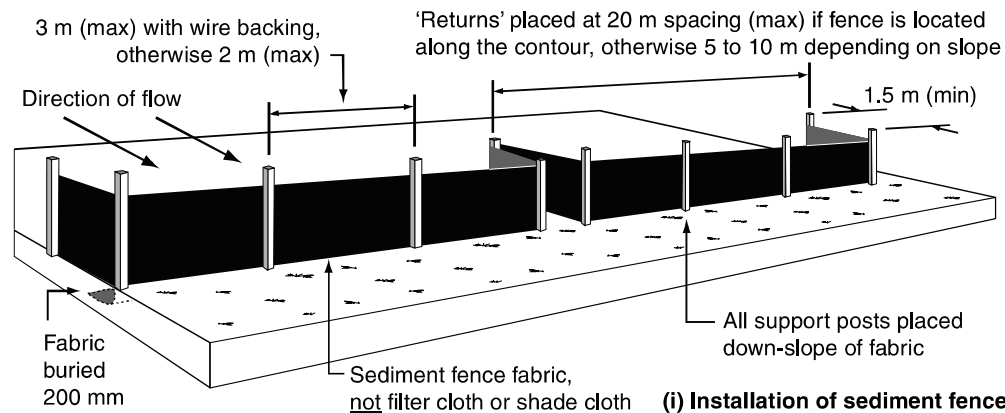
(f) Placement of up-slope straw bale



(g) Joining fabric - Method 2



(h) Installation with top wire support



(i) Installation of sediment fence

**Notes:**

1. Sediment fence to be installed along a line of constant ground elevation wherever practical.
2. Both end of the sediment fence to extend up the slope at least 1m.
3. Support post to be spaced a maximum 2m unless the fence is supported by a top wire or wire mesh backing, in which case 3m maximum spacing.
4. Fence 'returns' shall be installed at maximum 20m spacing if fence is installed along the contour, otherwise 5 to 10m maximum spacing.
5. Minimum 4 staples or tie wires per stake.

Drawn:	Date:		
GMW	Dec-09	Sediment Fence	SF-01



## MATERIALS

**FABRIC:** POLYPROPYLENE, POLYAMIDE, NYLON, POLYESTER, OR POLYETHYLENE WOVEN OR NON-WOVEN FABRIC, AT LEAST 700mm IN WIDTH AND A MINIMUM UNIT WEIGHT OF 140GSM. ALL FABRICS TO CONTAIN ULTRAVIOLET INHIBITORS AND STABILISERS TO PROVIDE A MINIMUM OF 6 MONTHS OF USEABLE CONSTRUCTION LIFE (ULTRAVIOLET STABILITY EXCEEDING 70%).

**FABRIC REINFORCEMENT:** WIRE OR STEEL MESH MINIMUM 14-GAUGE WITH A MAXIMUM MESH SPACING OF 200mm.

**SUPPORT POSTS/STAKES:** 1500mm<sup>2</sup> (MIN) HARDWOOD, 2500mm<sup>2</sup> (MIN) SOFTWOOD, OR 1.5kg/m (MIN) STEEL STAR PICKETS SUITABLE FOR ATTACHING FABRIC.

## INSTALLATION

1. REFER TO APPROVED PLANS FOR LOCATION, EXTENT, AND REQUIRED TYPE OF FABRIC (IF SPECIFIED). IF THERE ARE QUESTIONS OR PROBLEMS WITH THE LOCATION, EXTENT, FABRIC TYPE, OR METHOD OF INSTALLATION CONTACT THE ENGINEER OR RESPONSIBLE ON-SITE OFFICER FOR ASSISTANCE.

2. TO THE MAXIMUM DEGREE PRACTICAL, AND WHERE THE PLANS ALLOW, ENSURE THE FENCE IS LOCATED:

- (i) TOTALLY WITHIN THE PROPERTY BOUNDARIES;
- (ii) ALONG A LINE OF CONSTANT ELEVATION WHEREVER PRACTICAL;
- (iii) AT LEAST 2m FROM THE TOE OF ANY FILLING OPERATIONS THAT MAY RESULT IN SHIFTING SOIL/FILL DAMAGING THE FENCE.

3. INSTALL RETURNS WITHIN THE FENCE AT MAXIMUM 20m INTERVALS IF THE FENCE IS INSTALLED ALONG THE CONTOUR, OR 5 TO 10m MAXIMUM SPACING (DEPENDING ON SLOPE) IF THE FENCE IS INSTALLED AT AN ANGLE TO THE CONTOUR. THE 'RETURNS' SHALL CONSIST OF EITHER:

- (i) V-SHAPED SECTION EXTENDING AT LEAST 1.5m UP THE SLOPE; OR
- (ii) SANDBAG OR ROCK/AGGREGATE CHECK

DAM A MINIMUM 1/3 AND MAXIMUM 1/2 FENCE HEIGHT, AND EXTENDING AT LEAST 1.5m UP THE SLOPE.

4. ENSURE THE EXTREME ENDS OF THE FENCE ARE TURNED UP THE SLOPE AT LEAST 1.5m, OR AS NECESSARY, TO MINIMISE WATER BYPASSING AROUND THE FENCE.

5. ENSURE THE SEDIMENT FENCE IS INSTALLED IN A MANNER THAT AVOIDS THE CONCENTRATION OF FLOW ALONG THE FENCE, AND THE UNDESIRABLE DISCHARGE OF WATER AROUND THE ENDS OF THE FENCE.

6. IF THE SEDIMENT FENCE IS TO BE INSTALLED ALONG THE EDGE OF EXISTING TREES, ENSURE CARE IS TAKEN TO PROTECT THE TREES AND THEIR ROOT SYSTEMS DURING INSTALLATION OF THE FENCE. DO NOT ATTACH THE FABRIC TO THE TREES.

7. UNLESS DIRECTED BY THE SITE SUPERVISOR OR THE APPROVED PLANS, EXCAVATE A 200mm WIDE BY 200mm DEEP TRENCH ALONG THE PROPOSED FENCE LINE, PLACING THE EXCAVATED MATERIAL ON THE UP-SLOPE SIDE OF THE TRENCH.

8. ALONG THE LOWER SIDE OF THE TRENCH, APPROPRIATELY SECURE THE STAKES INTO THE GROUND SPACED NO GREATER THAN 3m IF SUPPORTED BY A TOP SUPPORT WIRE OR WEIR MESH BACKING, OTHERWISE NO GREATER THAN 2m.

9. IF SPECIFIED, SECURELY ATTACH THE SUPPORT WIRE OR MESH TO THE UP-SLOPE SIDE OF THE STAKES WITH THE MESH EXTENDING AT LEAST 200mm INTO THE EXCAVATED TRENCH. ENSURE THE MESH AND FABRIC IS ATTACHED TO THE UP-SLOPE SIDE OF THE STAKES EVEN WHEN DIRECTING A FENCE AROUND A CORNER OR SHARP CHANGE OF DIRECTION.

10. WHEREVER POSSIBLE, CONSTRUCT THE SEDIMENT FENCE FROM A CONTINUOUS ROLL OF FABRIC. TO JOIN FABRIC EITHER:  
(i) ATTACH EACH END TO TWO OVERLAPPING STAKES WITH THE FABRIC FOLDING AROUND THE ASSOCIATED STAKE ONE TURN, AND WITH

THE TWO STAKES TIED TOGETHER WITH WIRE; OR  
(ii) OVERLAP THE FABRIC TO THE NEXT ADJACENT SUPPORT POST.

11. SECURELY ATTACH THE FABRIC TO THE SUPPORT POSTS USING 25 X 12.5mm STAPLES, OR TIE WIRE AT MAXIMUM 150mm SPACING.

12. SECURELY ATTACH THE FABRIC TO THE SUPPORT WIRE/MESH (IF ANY) AT A MAXIMUM SPACING OF 1m.

13. ENSURE THE COMPLETED SEDIMENT FENCE IS AT LEAST 450mm, BUT NOT MORE THAN 700mm HIGH. IF A SPILL-THROUGH WEIR IS INSTALLED, ENSURE THE CREST OF THE WEIR IS AT LEAST 300mm ABOVE GROUND LEVEL.

14. BACKFILL THE TRENCH AND TAMP THE FILL TO FIRMLY ANCHOR THE BOTTOM OF THE FABRIC AND MESH TO PREVENT WATER FROM FLOWING UNDER THE FENCE.

## ADDITIONAL REQUIREMENTS FOR THE INSTALLATION OF A SPILL-THROUGH WEIR

1. LOCATE THE SPILL-THROUGH WEIR SUCH THAT THE WEIR CREST WILL BE LOWER THAN THE GROUND LEVEL AT EACH END OF THE FENCE.

2. ENSURE THE CREST OF THE SPILL-THROUGH WEIR IS AT LEAST 300mm THE GROUND ELEVATION.

3. SECURELY TIE A HORIZONTAL CROSS MEMBER (WEIR) TO THE SUPPORT POSTS/ STAKES EACH SIDE OF THE WEIR. CUT THE FABRIC DOWN THE SIDE OF EACH POST AND FOLD THE FABRIC OVER THE CROSS MEMBER AND APPROPRIATELY SECURE THE FABRIC.

4. INSTALL A SUITABLE SPLASH PAD AND/OR CHUTE IMMEDIATELY DOWN-SLOPE OF THE SPILL-THROUGH WEIR TO CONTROL SOIL EROSION AND APPROPRIATELY DISCHARGE THE CONCENTRATED FLOW PASSING OVER THE WEIR.

## MAINTENANCE

1. INSPECT THE SEDIMENT FENCE AT LEAST WEEKLY AND AFTER ANY SIGNIFICANT RAIN. MAKE NECESSARY REPAIRS IMMEDIATELY.

2. REPAIR ANY TORN SECTIONS WITH A CONTINUOUS PIECE OF FABRIC FROM POST TO POST.

3. WHEN MAKING REPAIRS, ALWAYS RESTORE THE SYSTEM TO ITS ORIGINAL CONFIGURATION UNLESS AN AMENDED LAYOUT IS REQUIRED OR SPECIFIED.

4. IF THE FENCE IS SAGGING BETWEEN STAKES, INSTALL ADDITIONAL SUPPORT POSTS.

5. REMOVE ACCUMULATED SEDIMENT IF THE SEDIMENT DEPOSIT EXCEEDS A DEPTH OF 1/3 THE HEIGHT OF THE FENCE.

6. DISPOSE OF SEDIMENT IN A SUITABLE MANNER THAT WILL NOT CAUSE AN EROSION OR POLLUTION HAZARD.

7. REPLACE THE FABRIC IF THE SERVICE LIFE OF THE EXISTING FABRIC EXCEEDS 6-MONTHS.

## REMOVAL

1. WHEN DISTURBED AREAS UP-SLOPE OF THE SEDIMENT FENCE ARE SUFFICIENTLY STABILISED TO RESTRAIN EROSION, THE FENCE MUST BE REMOVED.

2. REMOVE MATERIALS AND COLLECTED SEDIMENT AND DISPOSE OF IN A SUITABLE MANNER THAT WILL NOT CAUSE AN EROSION OR POLLUTION HAZARD.

3. REHABILITATE/REVEGETATE THE DISTURBED GROUND AS NECESSARY TO MINIMISE THE EROSION HAZARD.

Drawn:

GMW

Date:

Apr-10

Sediment Fence

SF-02

## APPLICATION

1. REFER TO APPROVED PLANS FOR LOCATION, EXTENT, AND APPLICATION DETAILS. IF THERE ARE QUESTIONS OR PROBLEMS WITH THE LOCATION, EXTENT, OR METHOD OF APPLICATION CONTACT THE ENGINEER OR RESPONSIBLE ON-SITE OFFICER FOR ASSISTANCE.

2. FILL OR SUITABLY CONTOUR ANY EXISTING RUTTING, RILLING OR GULLIES.

3. SUITABLY DIVERT UP-SLOPE STORMWATER RUNOFF AROUND TREATED AREA AS DIRECTED WITHIN THE APPROVED PLANS, OR OTHERWISE AS DIRECTED BY THE SITE ENGINEER.

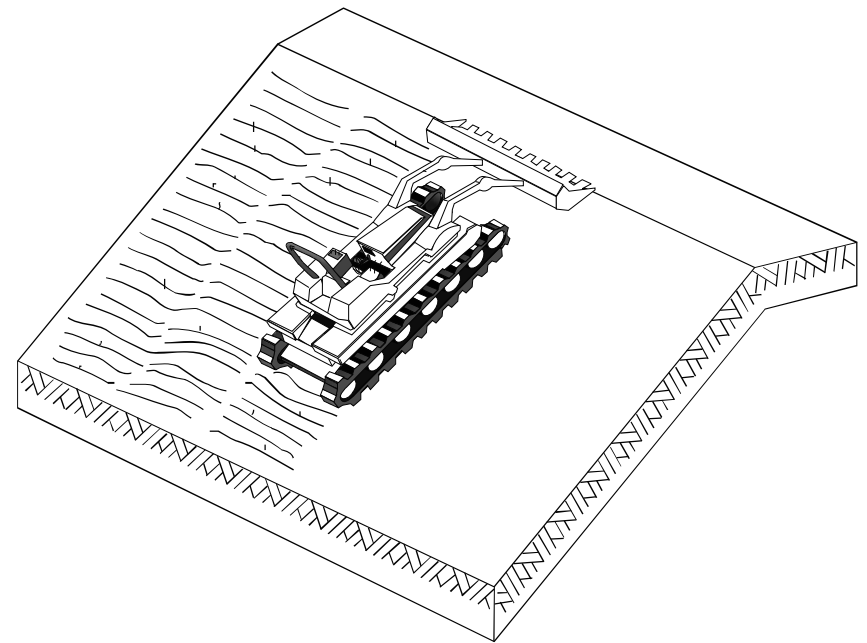
4. APPLY TREATMENT TO THE AREA TO THE DEPTH AND FREQUENCY (SPACING) SPECIFIED ON THE APPROVED PLANS, OR OTHERWISE AS DIRECTED BY THE SITE ENGINEER.

5. IMMEDIATELY SEED AND MULCH ROUGHENED AREAS TO OPTIMISE SEED GERMINATION AND GROWING CONDITIONS.

## MAINTENANCE

1. DURING THE CONSTRUCTION PERIOD, INSPECT THE TREATED AREA PRIOR TO FORECAST RAINFALL, DAILY DURING EXTENDED PERIODS OF RAINFALL, AFTER SIGNIFICANT RUNOFF PRODUCING RAINFALL, OR OTHERWISE ON A WEEKLY BASIS.

2. FILL EROSION RILLS SLIGHTLY ABOVE THE ORIGINAL GRADE, OR REGRADE THE SLOPE AS DIRECTED TO REMOVE THE RILLS.



**Figure 1 - Application of surface roughening on slope**

Drawn:	Date:		
GMW	Dec-09	Surface Roughening	SR-01



[ghd.com](http://ghd.com)

→ **The Power of Commitment**